



Operation Manual

CE 0086

medRAD[®] MRXperion
MR Injection System

- 1 Introduction 1**
 - 1.1 Certifications..... 1
 - 1.2 Intended Use..... 1
 - 1.3 Training Information..... 1
 - 1.4 Contraindications..... 1
 - 1.5 Restricted Sales 1
 - 1.6 Required Training 1
 - 1.7 Disclaimers..... 1

- 2 Symbols 3**
 - 2.1 Manufacturing Symbols 3
 - 2.2 Shipper Symbols..... 3
 - 2.3 Notified Body 4
 - 2.4 Regulatory Classifications..... 4
 - 2.5 MR Icons and Classifications..... 5
 - 2.6 Warning Labels and Symbols 5

- 3 Warnings, Cautions, and Notices 7**
 - 3.1 Warnings..... 7
 - 3.2 Cautions..... 8
 - 3.3 Notices..... 8

- 4 System Overview 9**
 - 4.1 System Diagram..... 9
 - 4.2 Moving the System..... 10
 - 4.3 Fluid Delivery Basics 11
 - 4.3.1 Protocol..... 11
 - 4.3.2 I Checked for Air 12
 - 4.3.3 Test Injection..... 12
 - 4.3.4 KVO (Keep Vein Open)..... 12
 - 4.3.5 Protocol Manager..... 12
 - 4.3.6 Fluid Delivery System Design 12
 - 4.3.7 Fluid Pressure and Pressure Limiting..... 13
 - 4.3.8 Response to Occlusions 13
 - 4.3.9 Volume and Flow Rate Protection 13
 - 4.4 Syringe Installation Features 13
 - 4.5 Basic Informatics 14
 - 4.6 Programming Mode..... 14
 - 4.7 Using the Pedestal with Integrated IV Pole..... 14

- 5 Understanding the Display and Pod 15**
 - 5.1 Home Screen 15
 - 5.2 Pod Description 18

- 6 Understanding the Injector Head..... 19**
 - 6.1 Injector Head Controls 19
 - 6.2 Injector Head Components 21
 - 6.2.1 Manual Knobs..... 21

7 System Lights and Indicators	23
7.1 Injector Head Lights and Indicators	23
7.2 Injector Status Lights.....	24
7.3 Pod Power Indicator.....	24
7.4 Hand Switch Light.....	25
8 Powering Up and Shutting Down the System	27
8.1 Powering Up the System.....	27
8.2 Powering Down the System	28
8.2.1 Hard Shutdown.....	28
8.3 Restore from Injector Shutdown.....	28
8.4 Restore from System Shutdown.....	28
9 Calculators.....	29
9.1 Enabling Calculators.....	29
9.2 Calculator Setup	29
9.2.1 Setting Up the eGFR Calculator.....	30
9.2.2 Setting Up the Weight-Based Dosing Calculator.....	34
9.3 Using the Calculators.....	34
9.3.1 Using the eGFR Calculator	34
9.3.2 Using the Weight Based Dosing Calculator	35
10 Protocol Management.....	37
10.1 Create or Edit a Protocol	37
10.2 Save a Protocol	40
10.3 Recall a Saved Protocol	41
11 Preparing for Injection	43
11.1 Control Room Preparation.....	44
11.1.1 Prepare Injection Protocol	44
11.2 Scan Room Preparation	44
11.2.1 Installing a Syringe	44
11.2.2 Filling a Syringe: Automatically or Manually	45
11.2.3 Attach and Prime the Tubing	46
11.2.4 Connect the Tubing to Patient.....	47
12 Arming and Injecting	49
12.1 Add Volume Indicator	49
12.2 Arming the Injector.....	49
12.2.1 Arming from the Control Room	49
12.2.2 Arming from the Scan Room	51
12.3 Starting KVO (Optional)	51
12.4 Initiating an Injection	52
12.5 Operator Initiated Hold	52
12.6 Aborting an Injection	52
12.7 Viewing Injection Progress.....	53
12.8 Reminders	54

13	Completing an Injection	55
13.1	Injection Complete	55
13.2	Injection Aborted.....	56
13.3	Exiting Injection Complete	57
13.3.1	Conducting Another Injection	57
14	Removing Disposable Syringes and Connector Tube	59
14.1	Removing Disposable Syringes and Connector Tube.....	59
15	Advanced Configurations	61
15.1	System Setup	61
15.1.1	System Setup Configurable Items	62
15.2	Calculator Setup.....	62
15.3	Protocol Manager Setup.....	63
15.3.1	Delete a Protocol.....	63
15.3.2	Rearrange Protocol List.....	64
15.3.3	Hide/Show a Region	64
15.3.4	Rename a Region.....	65
15.4	Fluid Delivery Setup.....	65
15.4.1	Fluid Delivery Setup Configurable Items	67
15.4.2	Contrast Type Setup.....	67
15.5	Help	70
15.5.1	Accessing the Help System.....	70
15.6	Status	71
16	System Messages	73
16.1	Type 1 Messages.....	73
16.2	Type 2 Messages.....	73
16.3	Type 3 Messages.....	74
17	Maintenance and Checkout.....	75
17.1	Daily.....	75
17.1.1	Cleaning the Injector Head, Syringe Piston, Syringe Interface, and Scan Room Unit Power Supply	75
17.1.2	Cleaning the Pedestal.....	76
17.1.3	Inspecting the Injector Head and Mounting	76
17.1.4	Cleaning the Display.....	76
17.1.5	Inspecting the Display.....	76
17.2	Monthly	77
17.2.1	Operational Checkout.....	77
17.3	Annually	78
17.3.1	Injection System Calibration	78
17.3.2	Checking Electrical Leakage	78
18	Specifications.....	79
18.1	Display Specifications	79
18.1.1	Display Dimensions.....	79
18.1.2	Display Connections	79

18.1.3 Display Input Power Requirements.....	80
18.1.4 Pod Input Power Requirements	80
18.2 Injector (Scan Room Unit) Specifications.....	80
18.2.1 Injector (Scan Room Unit) Dimensions.....	80
18.2.2 Scan Room Unit Power Supply Dimensions.....	81
18.2.3 Input Power Requirements.....	81
18.3 Environmental Specifications.....	81
18.3.1 Non-Operating (Transportation and Storage).....	81
18.3.2 Operating.....	81
18.3.3 Protection Against Electrical Shock	82
18.3.4 EMI/RFI	82
18.3.5 Protection Against the Ingress of Fluids.....	82
18.3.6 Mode of Operation	82
18.4 System Capabilities	83
18.5 Approximate Heat Generation.....	83
18.6 Over and Under Infusion Protection	83
18.7 System Fluid Performance	84
18.8 System Performance.....	84
18.9 Forward and Reverse Controls.....	84
18.10 Ground Continuity.....	84
18.11 Classifications	84
19 Options and Accessories	85
19.1 MEDRAD® MRXperion MR Injection System.....	85
19.2 MEDRAD® MRXperion Injection System Syringe Kit.....	85
19.3 Hand Switch	85
19.4 IV Poles.....	85
19.5 Manuals.....	85
19.6 Penetration Panel Filter Kit.....	85
20 Compliance to EN/IEC 60601-1-2: 2007.....	87

1 Introduction

This manual applies to the MEDRAD® MRXperion MR Injection System, referred to as the system throughout this document. Read all of the information contained in this manual. Understanding this information will assist users in operating the system in a safe manner.

NOTE: Operating specifications and feature availability may vary by country. Check with local product representatives and refer to country-specific operating instructions.

1.1 Certifications

This device is equipped to operate at 100-240 VAC, 50/60 Hz and is designed to comply with IEC60601-1:2012 (Edition 3.1). Special precautions regarding ElectroMagnetic Compatibility (EMC) are required for installation and use of this injector system. Detailed EMC information can be found in ["Chapter 20 - Compliance to EN/IEC 60601-1-2: 2007"](#).

1.2 Intended Use

The MEDRAD® MRXperion Injection System is a syringe-based fluid delivery system indicated for delivery of contrast media and saline during MR procedures. It is intended to be used for the specific purpose of injecting intravenous MR contrast media and saline into the human vascular system for diagnostic studies in magnetic resonance imaging (MRI) applications with MRI scanners that have a magnetic field strength between 0.7 Tesla and 3.0 Tesla. Only trained healthcare professionals are intended to operate this device.

1.3 Training Information

This manual is intended as an extension of the user interface of the MEDRAD® MRXperion Injection System to provide procedural and technical information. Additional MEDRAD® MRXperion training information will be available in the following formats:

- ◆ On-site initial installation and additional training as requested
- ◆ MEDRAD® MRXperion Quick Guides
- ◆ Syringe instructions for use (IFU)

Please contact Bayer HealthCare Services or your local Bayer representative if any of these resources are needed.

1.4 Contraindications

None known.

1.5 Restricted Sales

Federal (USA) Law restricts this device to sale by or on the order of a physician.

1.6 Required Training

This device is intended to be used by individuals with adequate training and experience in magnetic resonance (MR) imaging diagnostic studies.

1.7 Disclaimers

External wiring and modifications disclaimers: Bayer disclaims liability for any modifications or interfaces with other equipment that are not in conformity with the specifications and information contained within this manual.



Accessory equipment connected to the device must be certified according to IEC60601-1:2012 (Edition 3.1). Anyone who connects additional equipment to the signal input or output part configures a medical system and is therefore responsible that the system complies with the requirements of the standard IEC60601-1:2012 (Edition 3.1). To obtain on-site consulting or consulting references, contact Bayer HealthCare Services.

The system is not intended to deliver contrast agents and/or saline to more than one patient from the same saline container and Bayer disclaims any and all liability or consequences resulting from use of the same container on more than one patient.









Use of syringes and other disposables from a source that is not approved by Bayer may cause injury as set forth herein and such use may also void the warranty associated with this product.

2 Symbols

2.1 Manufacturing Symbols

	Manufacturer
	Authorized representative in the European community

2.2 Shipper Symbols

	Temperature range
	Humidity range
	Atmospheric pressure range
	Serial number
	Catalog number
	This side up
	Keep dry
	Fragile

2.3 Notified Body



Indicates that this device conforms to the requirements of the European Medical Device Directive 93/42/EEC

2.4 Regulatory Classifications



Identifies a type BF applied part complying with EN 60601-1 standards



Medical - General Medical Equipment
As To Electrical Shock, Fire, and Mechanical Hazards Only
In accordance with ANSI/AAMI ES60601-1 (2005, 3rd Ed.)
CAN/CSA-C22.2 No. 60601 (2008),
IEC 60601-1: 3rd Ed.



See accompanying documentation. This symbol indicates the user shall refer to the instructions-for-use to ensure safe operation.

CLASS 1

Indicates the injection system is Class I medical equipment as defined by IEC60601-1:2012 (Edition 3.1) standards for protection from electric shock



Class II Equipment, Double Insulated.

IPX0

IPX0 Code that indicates non-protection against ingress of water (IEC 60529)

IPX1

IPX1 Code that specifies the degree of protection against vertically falling water drops (IEC 60529)



Indicates separate collection for Electrical and Electronic Equipment per Directive 2002/96/EC. Refer to the following website for additional information:
<http://www.medrad.com/en-us/resources/Pages/WEEE.aspx>



Indicates that this product contains certain toxic or hazardous substances or elements and can be used safely during its environmental protection use period, indicated by the number in the center of the logo. This product should be recycled immediately after its environmental protection use period has expired.



Identifies the Equipotential connection. The Equipotential Connector (EPC) is an electrically bonded terminal on the injector that is used as a connection point between other medical electrical equipment. The EPC's function is to minimize any voltage potentials differences between all connected equipment. The EPC is not designed to be an electrical safety ground.



Does not contain serviceable parts.



Indicates that a component contains an electrical fuse that can be replaced.

2.5 MR Icons and Classifications



MR Conditional

Has been demonstrated to pose no known hazards in a specified MR environment with specified conditions of use as defined by the ASTM International Standards for MRI Device Marking.



MR Unsafe

Known threat or poses a hazard in all MR environments as defined by the ASTM International Standards for MRI Device Marking.

2.6 Warning Labels and Symbols



Pushing prohibited in this area. Do not push the injector above this label.

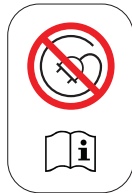

Do not coil the cable to the Power Supply on or near the injector or magnet. Excess cable should be tie wrapped in a figure-eight configuration and positioned as far away from the magnet as possible. Looped or coiled cable could create image artifacts.



Caster brakes must be used to prevent the injection system from drifting during use.

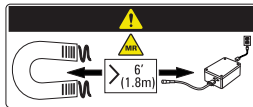

The injector (scan room unit) power supply must be more than 6ft (1.8m) away from the magnet.

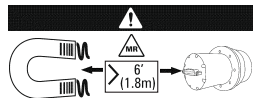

The optional Penetration Panel Filter must be more than 6ft (1.8m) away from the magnet.

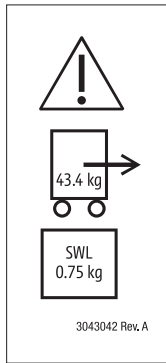

Caution:

Transportable Weight- 43.4kg

Safe Working Load- 0.75kg



Warning: Refer to warnings on Instructions for Use packaged in each carton.





Caution: Refer to cautions on Instructions for Use packaged in each carton.



Indicates hazardous voltage.



Consult operating instructions

 WARNING	Indicates that the information is a warning. Warnings advise you of circumstances that could result in injury or death to the patient or operator. Read and understand the warnings before operating the injection system.
 CAUTION	Indicates that the information is a caution. Cautions advise you of circumstances that could result in minor or moderate injury to the patient or operator. Read and understand the cautions before operating the injection system.
NOTICE	Indicates that the information is a notice. Notices advise you of circumstances that could result in damage to the device. Read and understand the notices before operating the injection system.

Note

Indicates that the information that follows is important information or a tip related to the proper functionality of the system that will help the operator to recover from an error or point to related information within the manual. Read and understand the notes before operating the system.

3 Warnings, Cautions, and Notices

3.1 Warnings



WARNINGS

Air Embolism Hazard - Serious patient injury or death may result.

- ◆ Use only Bayer approved syringes, connector tubing, and spikes.
- ◆ Use only catheters and connectors with pressure ratings that are compatible with this system.
- ◆ Use only accessories and options approved by Bayer.
- ◆ The operator needs to check for air to confirm that the syringes and tubing have been inspected for the presence of air.

Environmental Contamination Hazard - Serious patient or worker injury or death may result.

- ◆ Visually inspect all components before use.
- ◆ Do not use damaged components.

Electric Shock Hazard - Serious patient and/or worker injury or death may result.

- ◆ Only use the power cord supplied with the system or by the Bayer HealthCare Services representative.
- ◆ Equipment must only be connected to a supply mains with protective earth.
- ◆ Do not remove or open any enclosure, as hazardous voltages exist within system components.
- ◆ Do not immerse any system components in water or soap solutions.
- ◆ Disconnect the system from supply mains before cleaning.
- ◆ Do not use the system if any worn or damaged cabling is detected. Contact Bayer HealthCare Services for replacement.

Fire Hazard - Serious patient and/or worker injury or death may result.

- ◆ Use the correct fuse type.
- ◆ Fuse should only be replaced by Bayer or Bayer-trained personnel.

Explosion Hazard - Serious patient and/or worker injury or death may result.

- ◆ The system contains a lithium ion battery pack. Replacement and disposal shall be performed only by a qualified service engineer. Please contact Bayer HealthCare Services for assistance.

Compromised Efficacy Hazard - Serious patient injury or death may result.

- ◆ Do not use this system to deliver any fluid other than intravenous MR contrast media and saline.
- ◆ Do not retract pistons with connector tube installed.

Procedure Delay Hazard - Serious patient and/or worker injury or death may result.

- ◆ Turn off any other equipment that could generate high electromagnetic fields or high-level electrostatic discharge.

Personal injury or equipment damage may result when standing on the Power Supply Enclosure.

- ◆ Do not stand on the power supply enclosure.

WARNINGS

Patient and/or worker injury or equipment damage may result.

- ◆ Display is MR unsafe. The display is a known threat or poses a hazard in all MR environments as defined by the ASTM International Standards for MRI Device Marketing.
- ◆ The Injector (scan room unit) and power supply are MR conditional. The scan room unit and power supply have been demonstrated to pose no known hazards in a specific MR environment with specified conditions of use as defined by the ASTM International Standards for MRI Device Marketing.
- ◆ Do not make any unauthorized modifications to the injector or any of its parts.

3.2 Cautions

CAUTIONS

Mechanical Hazard - Minor or moderate patient and/or worker injury may result.

- ◆ Only use the system as defined in this manual. Follow the instructions given in system communication or fault messages.
- ◆ Do not use the system in the presence of flammable (such as anesthetics) or combustible gases or other agents.
- ◆ Use only non-magnetic tools to install any scanner/magnet room components.
- ◆ Dispose of system components and accessories according to local regulations or contact Bayer HealthCare Services.
- ◆ When moving the system, hold the pedestal no higher than 45inches (114.3 cm) above the floor.

Electric Shock Hazard - Minor or moderate patient and/or worker injury may result.

- ◆ Only plug the system into a direct mains access point.
- ◆ Make sure the direct mains access point is accessible during operation of the system.
- ◆ Do not plug the system power cords into an extension cord or multi-outlet power strip.
- ◆ Verify that the voltage and frequency as labeled matches the voltage and frequency of the electrical outlet.
- ◆ Use only Bayer-approved accessories.

Do not adjust or transport the system with fluid containers attached. Minor or moderate patient and/or worker injury may result.

- ◆ The fluid containers and/or holder may fall, causing patient injury and/or property damage.
- ◆ Attach containers only after the system is in a stationary position.

3.3 Notices

NOTICE

Electro-Mechanical Hazard - Equipment Damage may result.

- ◆ Do not use the system immediately after it has been brought indoors from extreme outside temperatures.
- ◆ Allow the system to stabilize at room temperature before use.
- ◆ Condensation may cause electrical damage to the injection system.

Mechanical Hazard - Equipment Damage may result.

- ◆ Do not touch the display screen with a sharp object.
- ◆ Component damage may occur if not installed properly. Ensure all connections are secure; do not over-tighten. This will help minimize leaks, disconnection, and component damage.

4 System Overview

4.1 System Diagram

The system is comprised of a scan room unit (injector) and a control room unit (touch screen display and Pod). These components are connected by a fiber optic communications link.

NOTE: When using the system with an open-bore scanner, it is recommended that the injector be placed a minimum of 60 inches (152.4 cm) from the facade of the scanner.

NOTE: When using the system with a Siemens MAGNETOM 1.5T or 3.0T scanner, it is recommended that the injector be placed a minimum of 18 inches (45.72 cm) from the facade of the scanner.

NOTE: Consider limits on the length of the connector tubing and patient position when placing the injector.

NOTE: Do not place the scan room unit in a magnetic field greater than 1000G without the casters being locked.

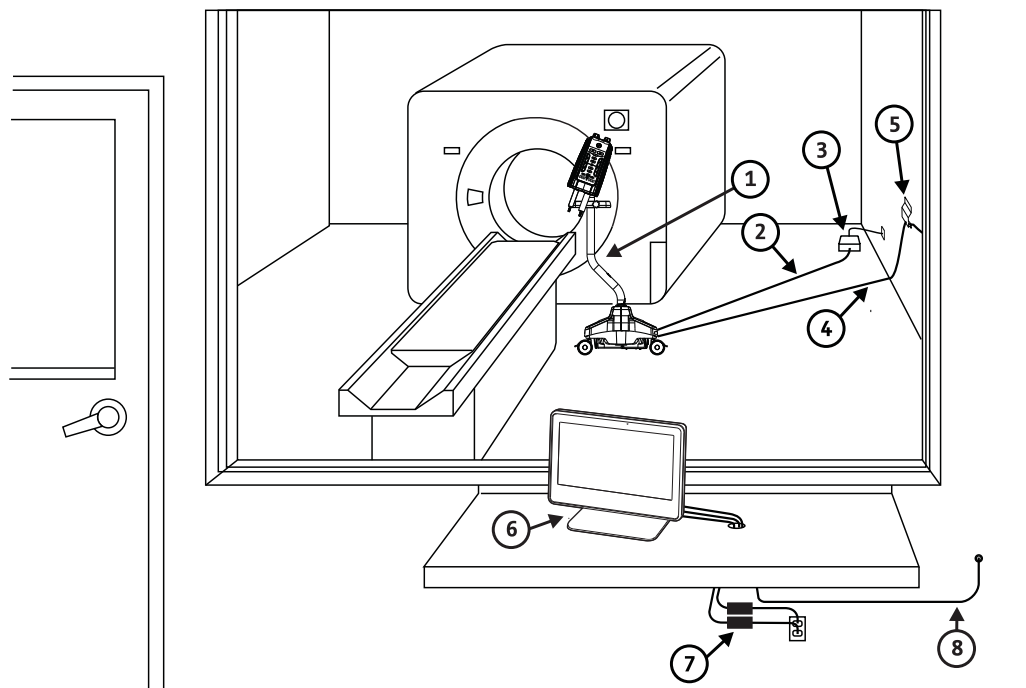

Figure 4 - 1: System Diagram - Power Supply in Scanner Room

Scan Room	Control Room
1 - Scan Room Unit (Injector)	6 - Control Room Unit (Display and Pod)
2 - Power Cable	7 - Display and Pod Power Supplies
3 - Scan Room Unit Power Supply	8 - Fiber Optic Communication Link
4 - Fiber Optic Communication Link	
5- Fiber Optic Quick Disconnect	

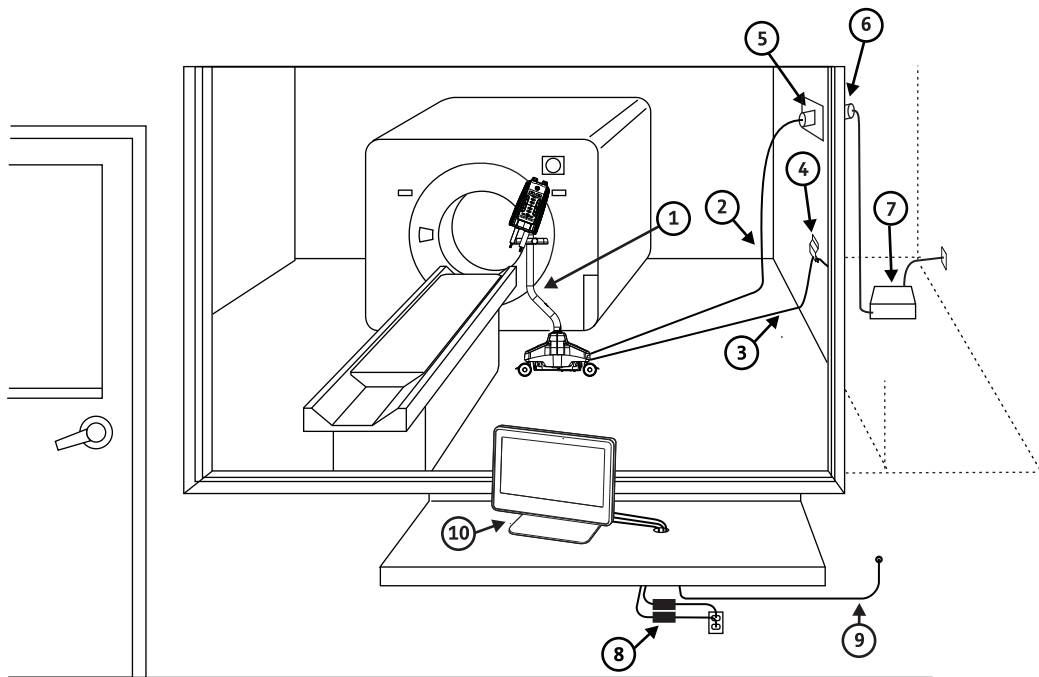

Figure 4 - 2: System Diagram - Power Supply Outside Scanner Room

Scan Room	Control Room and MRI Equipment Room
1 - Scan Room Unit (Injector)	6 - Penetration Panel Filter
2 - Power Cable	7 - Scan Room Unit Power Supply
3 - Fiber Optic Communication Link	8 - Display and Pod Power Supplies
4 - Fiber Optic Quick Disconnect	9 - Fiber Optic Communication link
5- Penetration Panel	10- Control Room Unit (Display and Pod)

4.2 Moving the System

⚠ WARNING

Patient injury could result from movement of the scan room unit (injector) after the patient is connected to the fluid path.

- ◆ Do not move the injector with the patient connected.
- ◆ Lock the casters at the base of the unit to prevent unintended movement.

Prior to moving the system, ensure that:

- ◆ the patient is disconnected
- ◆ the injector head is sitting above the base of the system
- ◆ there are no fluid containers attached

Once the injector head column is in place, move the system by holding the handle or by holding the pedestal below the point indicated by the label on the pedestal arm.

1. To rotate the injector head column, turn the knob at the base of the injector head column counterclockwise to unlock it.
2. Rotate the injector head column so the injector head sits above the base as shown in Figure 4 - 3.
3. Once the injector head has been moved into place, turn the knob clockwise to lock the column to prevent the injector head from rotating about the column.
4. Lock the casters at the base of the unit to prevent unintended movement.



Lock Symbol: Indicates which direction to turn the knob to lock or unlock the column. Locking the column prevents rotating the injector head about the column.

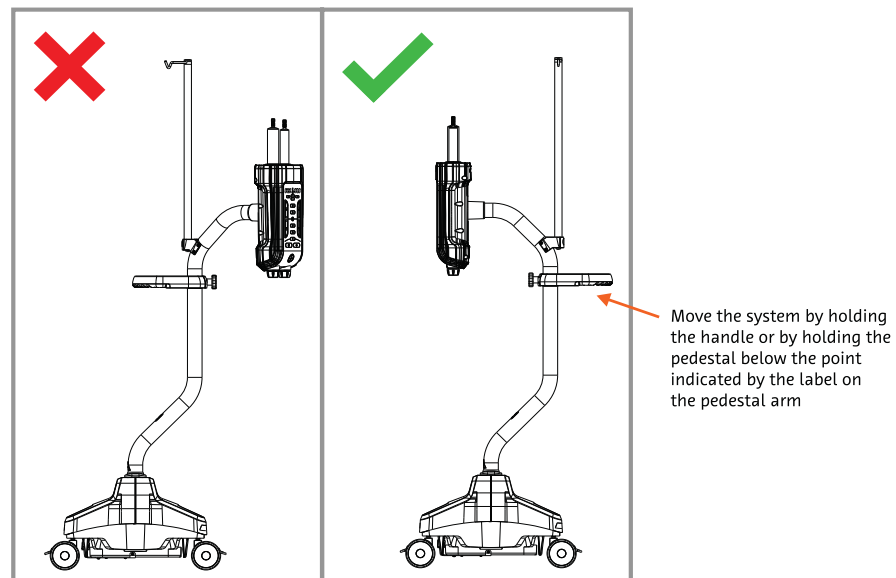

Figure 4 - 3: Moving the System

4.3 Fluid Delivery Basics

The system is a programmable power injector that enables an operator to generate a defined fluid delivery protocol and execute a fluid injection.

4.3.1 Protocol

A protocol defines how the fluid injection will proceed and is comprised of three elements: phases, a pressure limit, and optional reminders.

4.3.1.1 Phase

Phases are steps that define the actual movement of fluid, pauses, and/or holds.

There are three types of phases:

- ◆ **Fluid Delivery Phase:** Defines the flow rate, volume, and duration of a fluid to be injected.

- ◆ **Pause Phase:** Defines a set amount of time that fluid injection will be paused. The next phase will execute once the set time has elapsed.
- ◆ **Hold Phase:** Places the fluid delivery in Hold. The operator must press the “Start” button on the Pod, injector head or hand switch.

4.3.1.2 Pressure Limit

The pressure limit defines the maximum fluid pressure the system is permitted to generate during the execution of the protocol. The default maximum pressure limit is 325psi (2,240 kPa) when using the recommended disposable syringes from Bayer.

The operator may choose to reduce this pressure limit based on the conditions for use of the protocol.

4.3.1.3 Reminders

Reminders are optional, operator-defined timing notifications that appear during the injection sequence or after the sequence completes. Reminders provide a notification to the operator after a defined time has elapsed.

There are two types of reminders:

- ◆ Standard reminders: Occur during the protocol execution and are triggered by the initiation of the injection.
- ◆ Post-injection reminders: Occur after the protocol is complete and are triggered by the completion of the injection prior to disconnecting the patient.

4.3.2 I Checked for Air

Before the system can be armed, the operator must visually check that all air has been expelled from the syringes and tubing. After the operator has determined that all air has been expelled from the syringes and tubing, the operator can either press the I Checked for Air confirmation button, or acknowledge on the notification screen on the display.

4.3.3 Test Injection

An optional, operator-defined saline test injection can be delivered before the protocol is initiated.

4.3.4 KVO (Keep Vein Open)

An operator-defined function that delivers small boluses of saline from Syringe B at configurable intervals during programming, pre-and post-injection, between multiple injections, and/or during Pause and Hold phases.

4.3.5 Protocol Manager

Using Protocol Manager, the operator can name, save, and recall protocols.

4.3.6 Fluid Delivery System Design

The system is flow-controlled by three parameters: flow rate, duration, and volume. The system permits the operator to define any two of these three parameters and will automatically calculate the third:

- ◆ The flow rate specified in a phase is the value the system targets to deliver during the injection until the defined phase volume is delivered.
- ◆ The duration is the defined time the phase will take to perform the volume injection at the stated flow rate.
- ◆ Volume is the amount of fluid that will be delivered in a phase.

4.3.7 Fluid Pressure and Pressure Limiting

The fluid pressure is measured by the system during the execution of a phase and ensures the protocol Pressure Limit is not exceeded. Fluid pressure is dependent on the following:

- ◆ Flow rate
- ◆ Fluid viscosity
- ◆ Fluid temperatures
- ◆ Attached syringes and connector tube
- ◆ Catheter type/size

Pressure Limiting occurs when the measured fluid pressure exceeds the protocol Pressure Limit setting. If this occurs, the system informs the operator of the condition and initiates Flow Rate Reduction for the Fluid Delivery phase to reduce the fluid pressure.

4.3.7.1 Flow Rate Reduction

A slower flow rate is automatically initiated by the system to prevent the fluid pressure from exceeding the Pressure Limit. The system will deliver the phase volume at this reduced flow rate. The fluid delivery phase will exceed the programmed duration when Flow Rate Reduction occurs.

4.3.8 Response to Occlusions

When injecting into an occlusion, a stall condition or high pressure disarm results. A stall condition occurs when the actual flow rate is less than 10% of the defined rate. If a stall or high pressure disarm occurs, check the fluid path for blockage and inspect the syringes and connector tube for damage or kinks. If no issue is found, consider increasing the catheter size, removing administration sets, or decreasing the flow rate.

If an occlusion occurs during KVO, the system will detect the condition after 4 or less KVO boluses fail to be delivered. (The occlusion will be detected after 1 minute or less if the KVO interval is set to 15 seconds or after 5 minutes or less if the KVO interval is set to 75 seconds.) Refer to "[Section 15.4 - Fluid Delivery Setup](#)" for information about setting KVO intervals.

4.3.9 Volume and Flow Rate Protection

The system provides the following protection against over and under volume or flow rate conditions:

- ◆ Warnings on the Safety Screen to remind the operator to check the protocol prior to the system being armed.
- ◆ On-screen indications of insufficient volume when the total programmed volume is greater than the amount of fluid in the syringe.
- ◆ Injection monitoring to detect over flow rate or over volume conditions due to system faults. If either of these conditions is detected, the injection is stopped.

4.4 Syringe Installation Features

CAUTION

Mechanical Hazard - Minor or moderate patient and/or worker injury may result.

- ◆ Ensure the syringe is properly snapped into the front of the injector head before injecting.
- ◆ Improper engagement or rotating syringe may cause the syringe to leak, become damaged, or to disengage from the injector head during the injection.

The system is designed with four features that decrease the time and steps to install and remove syringes to the injector head. (For more information about configuration of these features, see "[Section 15.4 - Fluid Delivery Setup](#)".)

1. **Non-rotational orientation:** When installing a syringe onto the injector head, alignment is unnecessary. Push the 65mL syringe into opening A and the 115mL syringe into opening B.

2. **Auto Docking:** When Auto Advance is configured to be ON and a new empty syringe is installed, the injector piston automatically advances and docks with the syringe plunger.
3. **Auto Advance:** When Auto Advance is configured to be ON and a new empty syringe is installed on the injector head, the piston automatically docks with the syringe plunger and advances it to the full forward position.
4. **Auto Retract:** When Auto Retract is configured to be ON and the syringe is removed, the piston rod will automatically retract into the injector head.

4.5 Basic Informatics

If the optional Informatics platform is included with the system, please refer to the Certegra Workstation Informatics Panel and Modality Worklist Operations Manual for overview and functionality.

4.6 Programming Mode

The system allows the operator to enter values for two of the three parameters in the Fluid Delivery Phase. Based upon these operator-defined values, the system calculates the value of the third parameter. The system default configuration is for the operator to enter values for flow rate and volume and the system calculates the duration. Using Programming Mode (see "[Section 15.4 - Fluid Delivery Setup](#)"), the operator can select which of the three parameters (flow rate, volume, or duration) the system will automatically calculate based on their entries for the remaining two parameters.

4.7 Using the Pedestal with Integrated IV Pole

The pedestal with integrated IV pole is on casters and can be located anywhere within the MR scan room to facilitate the enhanced MRI procedure.

WARNINGS

Electric Shock Hazard - Serious patient and/or worker injury or death may result.

- ◆ Turn off any equipment that could generate a high level electrostatic charge.

CAUTIONS

Mechanical Hazard - Minor or moderate patient and/or worker injury may result.

- ◆ Tighten all screws, clamps, and knobs during assembly and as needed during use. Loose components may cause the pedestal to collapse.
- ◆ Do not move or manipulate the injector by pulling or pushing the integrated IV pole. Using the IV pole to maneuver the injector could bend the IV pole or cause the injector to fall over. Maneuver the injector as instructed in "[Section 4.2 - Moving the System](#)".
- ◆ Do not move the injector when anything is hanging on the Integrated IV pole.
- ◆ Use care and diligence in folding and unfolding the IV pole hooks. Keep hands and fingers clear of all pinch point areas.
- ◆ The IV pole folding hooks are designed to hold a maximum weight of 0.33 lbs (0.15 kg) or 150mL of fluid. Do not exceed the weight limit.
- ◆ Do not coil or hang cables from the IV pole.
- ◆ The pedestal is intended to support the injector head in an MR scanner room. Do not attempt to use the pedestal for any other purposes.

Electric Shock Hazard - Minor or moderate patient and/or worker injury may result.

- ◆ Only plug the system into a direct AC outlet.
- ◆ Do not plug the system power cords into an extension cord or multi-outlet power strip.
- ◆ Use only approved adapters and accessories from Bayer.

5 Understanding the Display and Pod

5.1 Home Screen

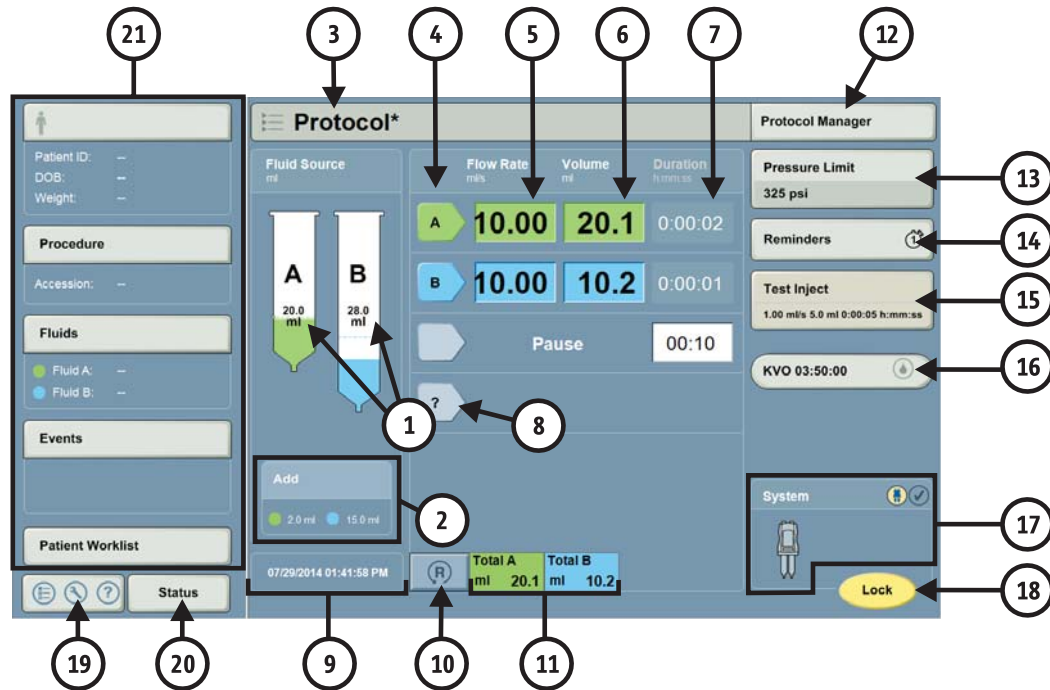







Figure 5 - 1: Home Screen

	Name	Icon (if applicable)	Description
1	Syringe Volume Information		Shows the volume in the syringes. An outline of the syringe displays if no syringe is present. If applicable, a dotted line displays on the syringe graphic to indicate that there is not enough volume in the syringe to complete the current protocol.
2	Add Volume Indicator (if applicable)		If there is not enough volume in the syringe to complete the current protocol, the "Add" box displays the volume that needs to be added to complete the current protocol.
3	Protocol		Displays the name of the protocol. When modifications have been made to a protocol, an asterisk (*) appears to the right of the protocol name.
4	Phase Button (Edit Phase)		Displays the programmed phase type. Select to edit a phase type.
5	Flow Rate		Displays the programmed flow rate. Select to modify (if enabled).
6	Volume		Displays the programmed volume. Select to modify (if enabled).
7	Duration		Displays the duration of the programmed injection. Select to modify (if enabled).
8	Phase Button (New Phase)		Select to enter a new phase type.
9	Date and Time		Shows the current date and time.

	Name	Icon (if applicable)	Description
10	Reset		Resets the protocol to the default factory values.
11	Total Volume		Displays the total programmed volume per syringe or the total combined volume in both syringes. See " Section 15.4.1 - Fluid Delivery Setup Configurable Items " for more information.
12	Protocol Manager		Opens Protocol Manager. See " Figure 5 - 3: - Protocol Manager " for more information.
13	Pressure Limit		Displays the current pressure limit. Select to modify.
14	Reminders		Displays the number of set reminders. Select to add or modify.
15	Test Inject		Indicates the operator-defined test injection parameters. Select to modify parameters.
16	KVO		Administers small boluses of common flushing solution before and after the injection and during any hold or pause phases. Illuminates blue when KVO is activated.
17	System Information		For more information, see " Figure 5 - 2: - System Information " below.
18	Lock/Arm/Disarm		Select to lock a protocol, arm the injector, and disarm the injector.
19	Launch Menu		For more information, see " Figure 5 - 4: - Launch Menu "
20	Status		Displays system status or alerts.
21	Informatics Panel		Displays Informatics Panel.

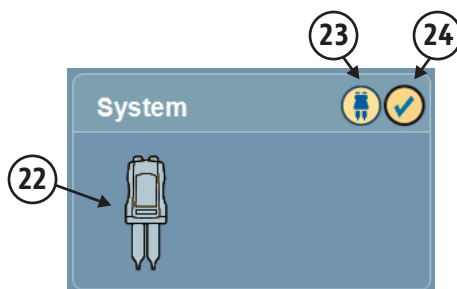
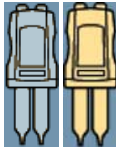



Figure 5 - 2: System Information

	Name	Icon	Description
22	Injector icon		<p>The Injector icon identifies various states of the injector:</p> <ul style="list-style-type: none"> ◆ not illuminated when the system is in the idle state. ◆ illuminates yellow and blinks when the system is armed. ◆ illuminates continuously yellow when the system is injecting.

	Name	Icon	Description
23	Injector Communicator		Illuminates yellow when in active communication with injector head.
24	I Checked for Air Indicator		Illuminates yellow when the operator has confirmed that the syringes and tubing have been inspected for the presence of air.

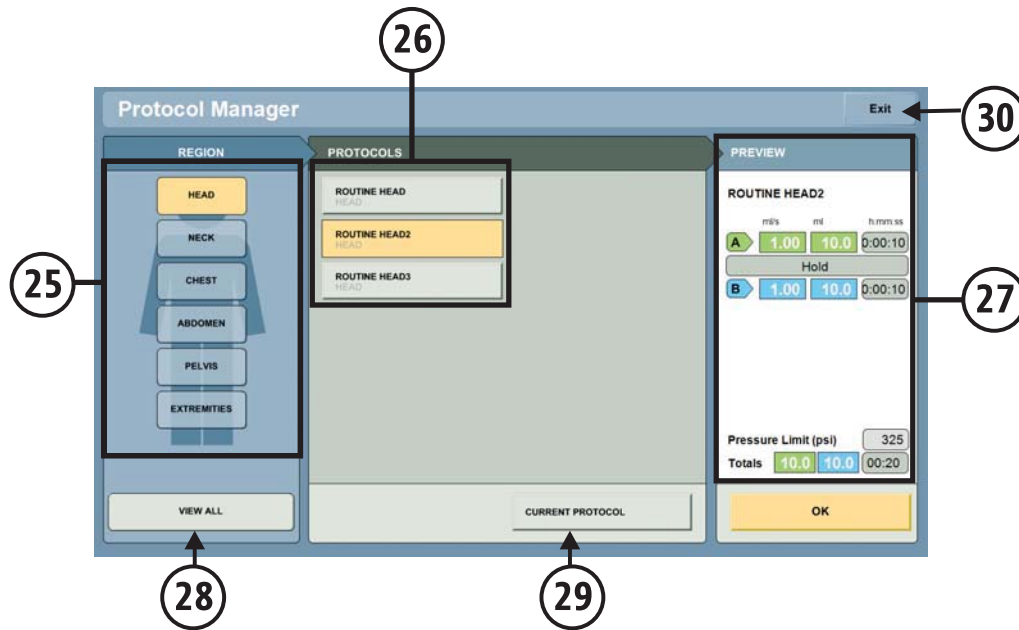

Figure 5 - 3: Protocol Manager

	Name	Description
25	Region of Interest	Shows list of regions in which protocols are stored.
26	Protocol List	List of protocols stored in the highlighted Region of Interest.
27	Protocol Preview	Displays details of selected protocol.
28	View All	Displays all stored protocols.
29	Current Protocol	Shows details for current protocol in use.
30	Exit	Returns to the Home Screen.

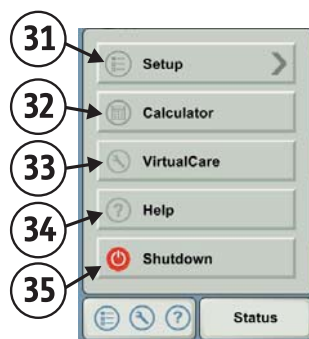
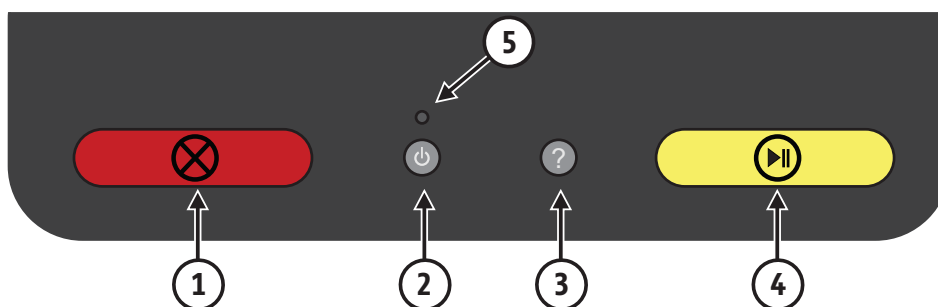

Figure 5 - 4: Launch Menu

	Name	Description
31	Setup	Accesses the Setup options. See " Chapter 15 - Advanced Configurations " for more information.
32	Calculators	Accesses the eGFR and Weight-Based Dosing calculators. Calculator button will only appear in the Launch Menu if one or more calculators are enabled.
33	Virtual Care	Displays the contact information for Bayer HealthCare Services and launches Service Applications if installed.
34	Help	Launches the Help system.
35	Shutdown	Accesses the Shutdown options.

5.2 Pod Description



	Name	Icon	Description
1	Abort		Terminates the injection and disarms the injector.
2	Power		Turns the system ON and OFF. Provides the operator with Shutdown options or System Restart. See " Chapter 8 - Powering Up and Shutting Down the System " for more information.
3	Help		Launches the Help System.
4	Start / Hold		Initiates an injection. When pressed after an injection has been initiated, puts the injection on hold.
5	Pod Power Indicator		Blinks or continuously illuminates amber or green, based on power status. See " Chapter 8 - Powering Up and Shutting Down the System " for more information.





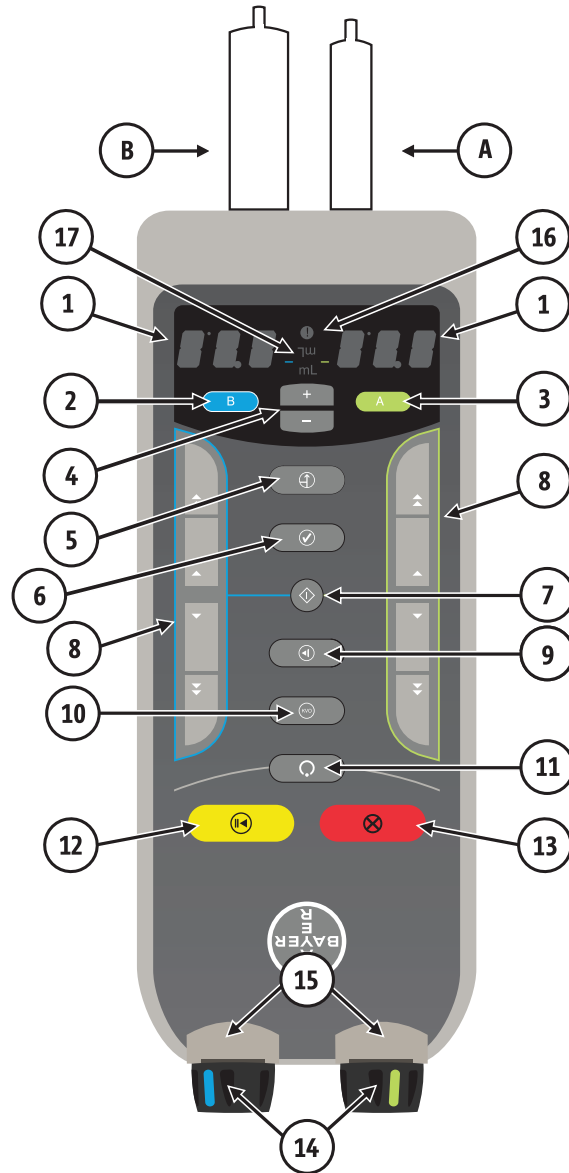



6 Understanding the Injector Head





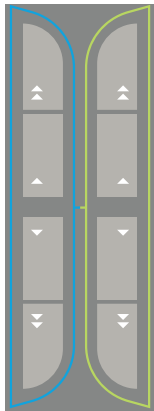

6.1 Injector Head Controls



NOTE: For more detailed information about injector head button light functionality, see "[Section - 7.1 - Injector Head Lights and Indicators](#)".

	Name	Icon (if applicable)	Description
A	Syringe A		Contrast Syringe
B	Syringe B		Saline Syringe
1	Volume Indicator (Side A or B)		Syringe not present: Displays dashes. Syringe present: Indicates the volume loaded in the syringe.

	Name	Icon (if applicable)	Description
2	Fill B		<p>Double press with injector head pointed upward: Fills Syringe B (Saline) to the displayed volume (Auto Fill).</p> <p>Single press: Displays Auto Fill volume for 10 seconds.</p> <p>The total Auto Fill volume for Syringe B includes:</p> <ul style="list-style-type: none"> ◆ the programmed injection volume ◆ volume to run KVO for 30 minutes (if KVO is enabled) ◆ prime volume (10 mL) if Syringe B is configured to be used for priming ◆ volume to perform a test injection (if Test Inject is enabled) <p>If test injections and KVO are enabled, the additional volume is included in the total whether or not KVO is used or a test injection is actually performed.</p>
3	Fill A		<p>Double press with injector head pointed upward: Fills Syringe A (Contrast) to the displayed volume (Auto Fill).</p> <p>Single press: Displays Auto Fill volume for 10 seconds.</p> <p>The total Auto Fill volume for Syringe A includes:</p> <ul style="list-style-type: none"> ◆ the programmed injection volume ◆ prime volume (10 mL) if Syringe A is configured to be used for priming
4	+/- Buttons		Adjusts the Auto Fill volume in increments/decrements of 1 mL. Can be used after a single press of the Fill A button or Fill B button. Illuminates to indicate that the operator can begin Auto Fill.
5	Prime		When pressed, activates the priming function. Illuminates to indicate that the operator can begin priming.
6	I Checked for Air Confirmation Button		When blinking, reminds the operator to examine the syringes and tubing for the presence of air. When illuminated, indicates that the operator has confirmed that the syringes and tubing have been inspected for the presence of air.
7	Enable Piston Control Button		Activates the forward and reverse piston controls. Deactivates after ten seconds of inactivity. Illuminates when active.
8	Forward and Reverse Piston Controls (Side A or B)		<p>Advances and retracts the piston (variable speed). Illuminates when enabled.</p> <p>  High speed  Low speed </p>

	Name	Icon (if applicable)	Description
9	Test Inject		When pressed, initiates a test injection based on operator-defined parameters. When blinking, indicates that the operator can perform a test inject to determine patency of the patient connection. The head must be oriented with the syringes pointed downward and the I Checked For Air must be confirmed to use this function.
10	KVO		When pressed, activates the KVO (Keep Vein Open) feature. When blinking, indicates that the operator can start KVO to maintain patency of the patient connection. The head must be oriented with the syringes pointed downward and the I Checked For Air must be confirmed to use this function.
11	Arm		When pressed, arms the system. The head must be oriented with the syringes pointed downward and the I Checked For Air must be confirmed to use this function.
12	Start / Hold		When pressed, initiates an injection when the system is Armed. When pressed during an injection, holds the injection.
13	Abort		When pressed, terminates the injection and disarms the injector.
14	Manual Knobs		Permits an operator to manually move the piston when the injector is not armed.
15	Injector Status Indicators		Armed and Injection Status Indicators.
16	Attention Indicator		Illuminates to alert the operator. See " Chapter 7 - System Lights and Indicators " for more information.
17	mL		Indicates fluid volume unit regardless of injector head orientation.

6.2 Injector Head Components

6.2.1 Manual Knobs

An operator can use the manual knobs to purge air, check patency of the patient connection by observing the back flow of blood, and to assist in ensuring correct catheter placement.

NOTE: For all non-automatic movements, it is critical for volume accuracy to ensure that the manual knob is turned one full turn clockwise after every reverse movement.

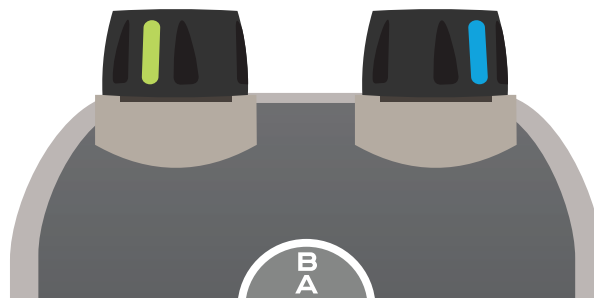









Figure 6 - 1: Injector Head Manual Knobs







7 System Lights and Indicators

7.1 Injector Head Lights and Indicators

The buttons on the injector head illuminate or blink depending on the conditions listed below:

Name	Button / Icon	Behavior / Event
+/- Buttons		<ul style="list-style-type: none"> Continuously illuminates white when Fill A button is pressed Continuously illuminates white when Fill B button is pressed. Blinks to indicate that the syringe volume should be increased or decreased
Enable Piston Control Button		<ul style="list-style-type: none"> Illuminates continuously when manual piston moving is enabled. Automatically disables after ten seconds of inactivity.
Forward and Reverse Piston Controls (Side A or B)		<ul style="list-style-type: none"> Illuminates when enabled
Arm Button		<ul style="list-style-type: none"> Blinks to prompt the operator when the injector is ready to Arm (I Checked for Air has been confirmed, protocol is locked from the display, injector head is tilted down) Illuminates continuously when pressed, indicating that system is Armed
Attention Indicator		<ul style="list-style-type: none"> Blinks fast to alert operator of error: head is tilted up after Test Inject, KVO, or Arm button is pressed Continuously illuminates amber during Full System Shutdown or Injector Shutdown Continuously illuminates amber when communication is lost between Pod and display Blinks amber when communication is lost between injector and display Illuminates Red to alert operator of a critical error.
Prime Button		<ul style="list-style-type: none"> Blinks slow to prompt the operator when to prime with the injector head tilted up Automatically stops blinking and is no longer illuminated after 30 seconds of inactivity or after the piston is manually moved Blinks fast during priming
Volume Display		<ul style="list-style-type: none"> Displays "--" when no syringe is installed Displays "--" when syringe is engaged, plunger not docked Displays actual volume when I Checked for Air confirmed, syringe engaged, plunger docked For key presses that the system is programmed to ignore, displays "--" and illuminates the Attention Indicator
Fill A Button		<ul style="list-style-type: none"> Illuminates continuously when pressed

Name	Button / Icon	Behavior / Event
Fill B Button		<ul style="list-style-type: none"> ◆ Illuminates continuously when pressed
KVO Button		<ul style="list-style-type: none"> ◆ Blinks to prompt the operator when KVO can be started ◆ Illuminates continuously when KVO is enabled
Test Inject Button		<ul style="list-style-type: none"> ◆ Blinks slow to prompt the operator when a test injection can be performed ◆ Blinks fast during Test Injection
I Checked for Air Confirmation Button		<ul style="list-style-type: none"> ◆ Blinks slow after priming to alert the operator to I Checked for Air ◆ Illuminates continuously when pressed, indicating that I Checked for Air is completed

7.2 Injector Status Lights

The injector head has two injector status lights that illuminate continuously or blink, depending on the conditions listed below. Syringe A illuminates **green** and Syringe B illuminates **blue**.



Table 7 - 1: Injector Status Light Functionality

Condition	Injector Status Light Description
Armed	The lights corresponding to the syringes to be used for the protocol blink.
Injecting	The light corresponding to the syringe that is moving remains illuminated.
Pause or Hold	The lights corresponding to the syringes to be used for the protocol blink.
KVO	The Syringe B light is illuminated during KVO.

7.3 Pod Power Indicator

Name	Button / Icon	Behavior / Event
Pod Power Indicator		<ul style="list-style-type: none"> ◆ Not illuminated when Pod is not connected to a power source ◆ Continuously illuminates amber during Full System Shutdown ◆ Continuously illuminates green when full system is ON ◆ Blinks green during Injector Shutdown

7.4 Hand Switch Light

The optional hand switch enables an operator to start, hold, and stop an injection. The hand switch contains a light that identifies the state of the injector. This light illuminates or blinks depending on the conditions below:

Table 7 - 2: Hand Switch Light Functionality

Condition	Hand Switch Light Description
Armed	The light blinks.
Injecting	The light illuminates.
Hold	The lights blinks.



8 Powering Up and Shutting Down the System

8.1 Powering Up the System

⚠ CAUTION

Electric Shock Hazard - Minor or moderate patient and/or worker injury may result.

- ◆ Verify that the voltage and frequency as labeled matches the voltage and frequency of the electrical outlet.

1. Press the power button on the Pod. The LED turns green and the display powers up.
2. Ensure the rocker switch on the Scan Room Unit Power Supply is set to ON ("I" is pressed in). The injector powers up.
3. The display will briefly show the system communication statuses and software versions.

NOTE: If a communication error is displayed, contact Bayer HealthCare Services.

4. Next, the Safety Screen will display. Read the warnings on the Safety Screen and select **Continue**.
5. The system powers up and the Home Screen is displayed.

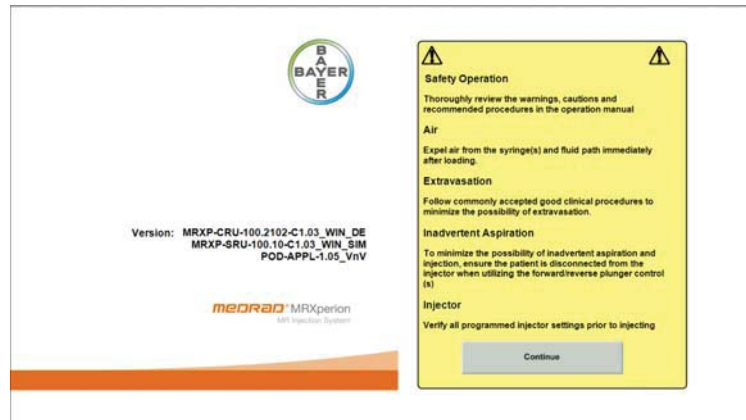
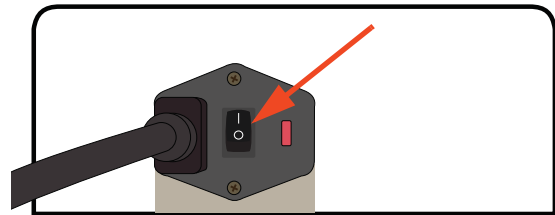

Figure 8 - 1: Safety Screen

8.2 Powering Down the System

The system provides three options for powering down the system: Full System Shutdown, Injector Shutdown, and System Restart.

1. From the Launch menu, select Shutdown, and then select a shutdown option or press the power button on the Pod.

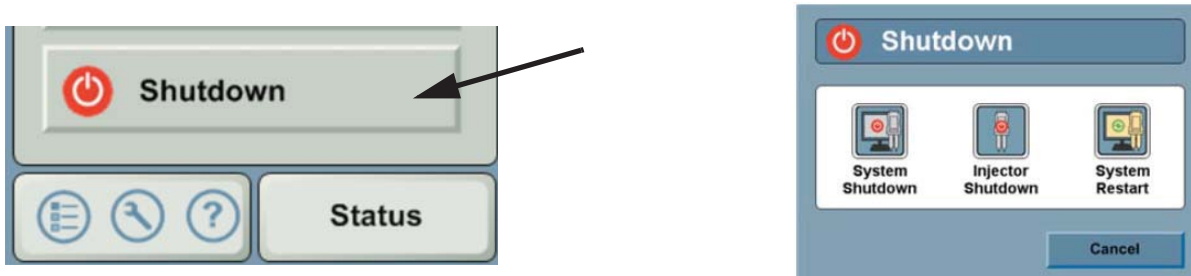

Figure 8 - 2: Power Down Options

2. Select from the following shutdown options:
 - ◆ **System Shutdown:** Both the display and the injector shutdown. The Pod LED illuminates continuous amber.
 - ◆ **Injector Shutdown:** The injector shuts down, the display screen is blank, and Informatics operations remain running on the display. The Pod LED blinks green.
 - ◆ **System Restart:** Both the display and the injector restart.

8.2.1 Hard Shutdown

To perform a hard shutdown, press and hold the power button on the Pod for at least 7 seconds. The injector and display shut down and the Pod LED flashes green.

8.3 Restore from Injector Shutdown

1. While the Pod LED blinks green, press the power button on the Pod.
2. The Pod LED will illuminate continuous green, the injector powers up, and the display screen becomes active.
3. Read the warning on the Safety screen, then press **Continue**. The Home Screen displays.

8.4 Restore from System Shutdown

1. While the Pod LED is illuminates continuous amber, press the power button on the Pod.
2. The Pod LED will illuminate continuous green, the injector powers up, and the display screen becomes active.

NOTE: Take care not to interrupt the restore cycle described in ["8.3"](#) and ["8.4"](#). If you inadvertently press the Pod power button while restoring from Injector Shutdown or System Shutdown, an error may be generated on the injector or the display.

9 Calculators

The system includes two calculators that can be used for determining weight-based dosing values and eGFR values.

⚠ CAUTIONS

Minor or moderate patient and/or worker injury may result.

- ◆ eGFR values are estimates. Decisions about the use of contrast media should be made by the on-site professionals.
- ◆ eGFR values derived from the operator of these algorithms are estimates and may be in error. That is, the estimated value may not reflect the actual status of the patient’s renal function. Values calculated may be under- or over-estimates of the patient’s actual renal status and are dependent on a variety of factors that are not included as variables in the algorithm.

NOTE: Adhere to all package insert instructions for use of contrast media

eGFR (Estimated Glomerular Filtration Rate) Calculator	Calculates an estimation of how well a patient’s kidneys are functioning using an operator-selected formula
Weight-Based Dosing Calculator	Calculates suggested dose of contrast media based on patient's weight, selected contrast and dosing factor

9.1 Enabling Calculators

By default, the eGFR and Weight Based Dosing calculators are not enabled on the system. Calculator and Calculator Setup will not appear in the Launch Menu until one or both calculators are enabled.

1. To enable the calculators, select **Setup** from the Launch Menu. Select **System Setup**.
2. Press the arrow button to access the second page of System Setup.
3. To enable the eGFR calculator, select the eGFR Calculator button, then select ON.
4. To enable the Weight Based Dosing calculator, select the Weight Based Dosing Calculator button, then select ON.
5. Select OK. Select Yes on the displayed message to save changes and return to the home screen.

9.2 Calculator Setup

Values, formulas and calculators must be chosen before use. Calculator Setup allows the operator to enable or disable eGFR formulas, set the units for creatinine and weight-based dosing, and configure the display of output ranges for the eGFR calculator.

1. To access Calculator Setup, select **Setup** from the Launch menu.
2. Select **Calculator Setup**.



Figure 9 - 1: Accessing Calculator Setup from the Setup menu.

The calculator setup can also be accessed from the Setup button on the Calculator screen.

1. From the launch menu, select **Calculator** (1).
2. Select the Setup button (2).

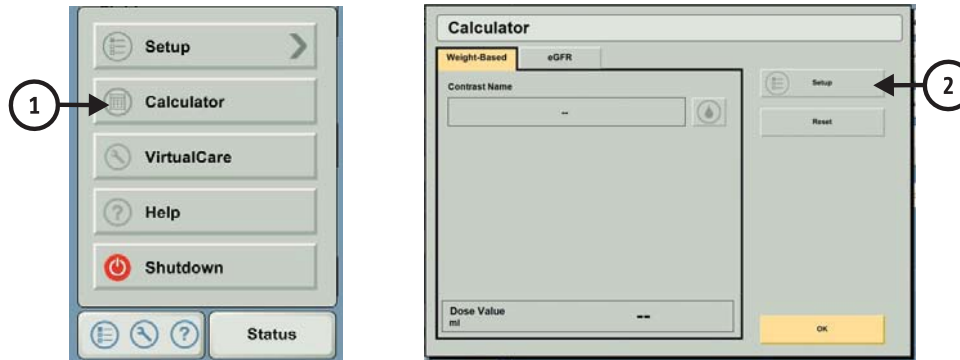
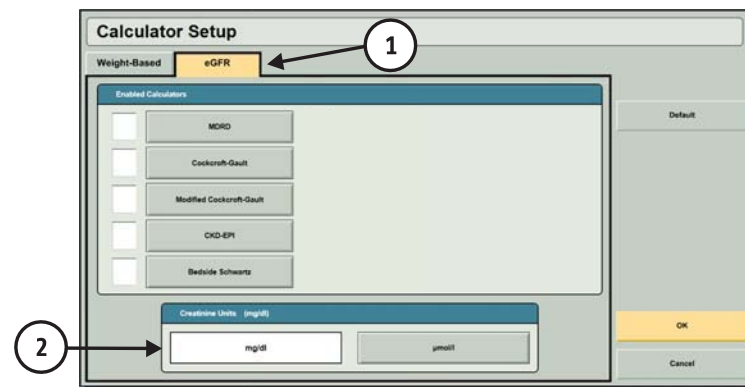

Figure 9 - 2: Accessing Calculator Setup from the Calculator screen

9.2.1 Setting Up the eGFR Calculator

1. Access the eGFR Calculator Setup by selecting the eGFR tab (1) on the Calculator Setup screen.
2. Select the creatinine units of measure at the bottom of the window (2).

NOTE: Serum creatinine values may be entered in conventional or SI units.



9.2.1.1 Enabling eGFR Formulas

1. Check the box next to a formula name to enable it (3).

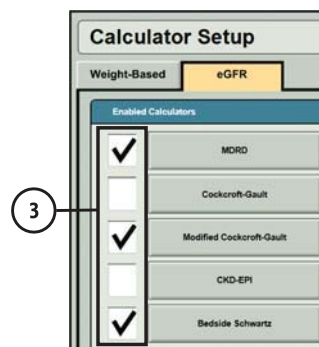

Figure 9 - 3: Enabling eGFR Formulas

NOTE: eGFR formulas have known limitations. Adhere to site policy and guidelines for proper use of these formulas.

- To view the formula details, select the formula name button. Click OK to close the message window.

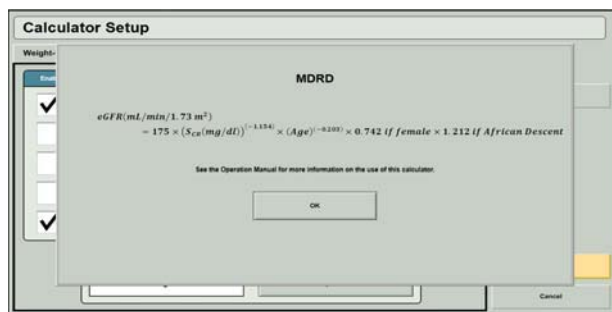

Figure 9 - 4: Viewing eGFR calculator formula

Table 9 - 1: eGFR Formulas

Calculator	Equation
MDRD (Modification of Diet in Renal Disease) (IDMS Traceable)	$eGFR \text{ (mL/min/1.73 m}^2\text{)} = 175 \times (S_{CR} \text{ (mg/dl)})^{-1.154} \times (\text{Age})^{-0.203} \times 0.742 \text{ if female} \times 1.212 \text{ if African Descent}$
Cockcroft-Gault	$C_{CR} 24 \text{ (mL/min)} = \frac{(140 - \text{Age} \times \text{Weight (kg)})}{72 \times S_{CR} \text{ (mg/dl)}} \times 0.85 \text{ if female}$
Modified Cockcroft-Gault	$eGFR \text{ (mL/min/1.73 m}^2\text{)} = \left[\frac{(140 - \text{Age} \times \text{Weight (kg)})}{72 \times S_{CR} \text{ (mg/dl)}} \times 0.85 \text{ if female} \right] \times \frac{1.73}{BSA}$ $BSA = \sqrt{\text{Height (cm)} \times \text{Weight (kg)} / 3600}$
CKD-EPI (Chronic Kidney Disease Epidemiology Collaboration)	$eGFR \text{ (mL/min/1.73 m}^2\text{)} = 141 \times ((\min(S_{CR} \text{ (mg/dl)} / 0.7 \text{ if female } 0.9 \text{ if male}), 1))^{(-0.329 \text{ if female } -0.411 \text{ if male})} \times \max(S_{CR} K, 1)^{-1.209} \times (0.993)^{\text{Age}} \times (1.018 \text{ if female}) \times (1.159 \text{ if African Descent})$
Bedside Schwartz (IDMS Traceable)	$eGFR \text{ (mL/min/1.73 m}^2\text{)} = \frac{0.41 \times \text{Height (cm)}}{S_{CR} \text{ (mg/dl)}}$

NOTE: MDRD, Cockcroft-Gault, Modified Cockcroft-Gault, and CKD-EPI calculators are intended to be used only for adults age 18 years or older. Bedside Schwartz is intended to be used only for children under 18 years of age. All formulas are only intended to be used with patient ages consistent with contrast package inserts.

NOTE: eGFR formulas have known limitations. Adhere to site policy and guidelines for proper use of these formulas.

NOTE: Known limitations regarding the Bedside Schwartz formula:

- Above a GFR of 90 mL/min/1.73m², the Schwartz formula may significantly overestimate eGFRs.
- Bedside Schwartz formula is not adjusted for age or sex, which can have a significant effect on the prediction of GFR.
- The lower serum creatinine concentration in most children makes the influence of a measurement error proportionally larger than the same magnitude error in an adult sample.
- The generally lower serum total protein in very young children can alter the relative magnitude of the influence of the nonspecific reaction of proteins in some Jaffe methods used to determine serum creatinine.

eGFR Calculator References:

- ◆ MDRD: Levey AS, Coresh J, Greene T, Stevens LA, Zhang YL, Hendriksen S, Kusek JW, Van Lente F; Chronic Kidney Disease Epidemiology Collaboration. Using standardized serum creatinine values in the modification of diet in renal disease study equation for estimating glomerular filtration rate. *Ann Intern Med.* 2006 Aug 15;145(4):247-54.
- ◆ Cockcroft-Gault/Modified Cockcroft-Gault: Cockcroft DW, Gault MH. Prediction of Creatinine Clearance from Serum Creatinine. *Nephron* 1976 16: 31- 41
- ◆ CKD-EPI: Levey AS, Stevens LA, et al. A New Equation to Estimate Glomerular Filtration Rate. *Ann Intern Med.* 2009; 150:604-612.
- ◆ Bedside Schwartz: Schwartz GJ, Muñoz A, Schneider MF, et al. New equations to estimate GFR in children with CKD. *J Am Soc Nephrol.* 2009;20(3):629-37.
- ◆ Bedside Schwartz: Schwartz GJ and Work DF. Measurement and estimation of GFR in children and adolescents. *Clin J Am Soc Nephrol.* 2009; 4 (11): 1832-43.
- ◆ Bedside Schwartz: Anja Gao, Francois Cachat, Mohamed Faouzi, Daniel Bardy, Dolores Mosig, Blaise-Julien Meyrat, Eric Girardin and Hassib Chehade. Comparison of the glomerular filtration rate in children by the new revised Schwartz formula and a new generalized formula. *Kidney International* (2013) 83, 524-530
- ◆ Bedside Schwartz: Hans Pottel & Felix M. Mottaghy & Zahur Zaman & Frank Martens. On the relationship between glomerular filtration rate and serum creatinine in children. *Pediatr Nephrol* (2010) 25:927-934
- ◆ Bedside Schwartz: Justine Bacchetta, Pierre Cochat, Nicolas Rognant, Bruno Ranchin, Aoumeur Hadj-Aissa, and Laurence Dubourg. Which Creatinine and Cystatin C Equations Can Be Reliably Used in Children?. *Clin J Am Soc Nephrol* 6: 552-560, 2011

9.2.1.2 Display Output Range Setup - Optional

The system provides three options for configuring the eGFR display:

- ◆ No ranges
- ◆ Ranges without colors
- ◆ Ranges with system-assigned colors

NOTE: There are no default range settings for the Cockcroft-Gault formula. All other formulas have the default setting of 0 to 30 ml/min/1.73 m² for Range 1. Default settings can be changed to user preferences.

To configure the system to display ranges (with or without colors):

1. To setup Display Output Ranges, check the Display Output Ranges box next to the enabled formula.
2. Select **Edit** to configure parameters for each range individually.

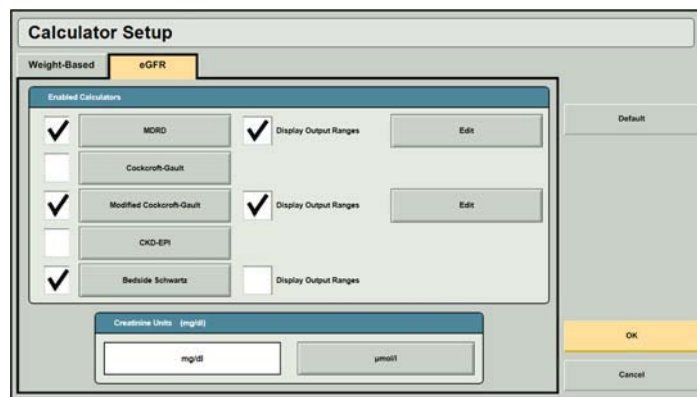

Figure 9 - 5: Display Output Range Setup

3. From the drop down menu, select the number of ranges (1).
4. Enter the maximum value for each range by selecting the field (2) and entering the numbers using the keypad. Select **Enter** to confirm value. The starting value for the next range will be automatically calculated and populated.
5. Repeat step 4 for additional ranges.
6. **Optionally**, select Color (3) to assign color to ranges.

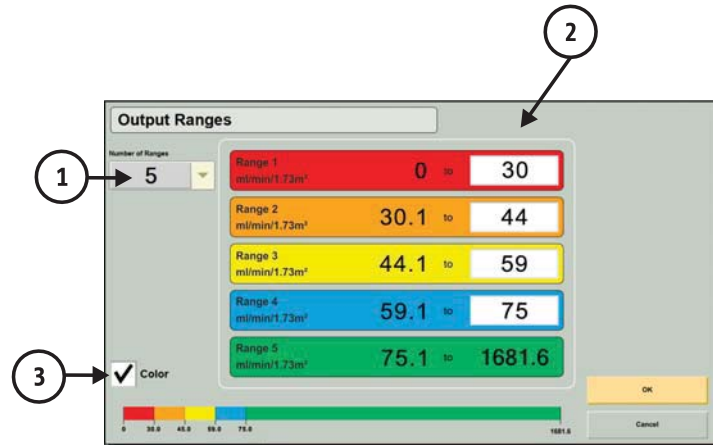

Figure 9 - 6: Display Output Range Configuration

- ◆ The color of each range will vary depending on the selected number of ranges. Refer to the following chart for the range colors:

# of Ranges:	Range 1	Range 2	Range 3	Range 4	Range 5
2 Ranges	Red	Green			
3 Ranges	Red	Yellow	Green		
4 Ranges	Red	Yellow	Blue	Green	
5 Ranges	Red	Orange	Yellow	Blue	Green

7. When maximum values have been assigned to all ranges, select OK to save and return to the Calculator Setup screen.
8. Select OK on the Calculator Setup screen to save changes and return to the previous screen.

9.2.2 Setting Up the Weight-Based Dosing Calculator

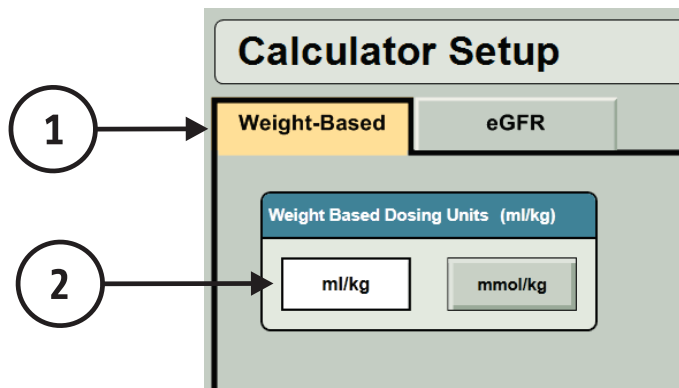

Figure 9 - 7: Defining Dosing Unit - Weight-Based Dosing Calculator

1. Access the Weight-Based Dosing Calculator setup by selecting the Weight-Based tab (1) on the Calculator Setup screen.
2. Define a dosing unit from the pick list (2). (Note: This selection will overwrite the dosing unit defined in System Setup if the selected units vary. See "[Section 15.1 - System Setup](#)" for more information.)
3. Select OK to save changes and return to the previous screen.

9.3 Using the Calculators

1. From the Launch menu, select Calculator.
2. Select the tab of an enabled calculator.

9.3.1 Using the eGFR Calculator

NOTE: The eGFR calculator feature provided on this system is intended to be a point-of-care application. Adhere to site policy and guidelines when using the calculator feature.

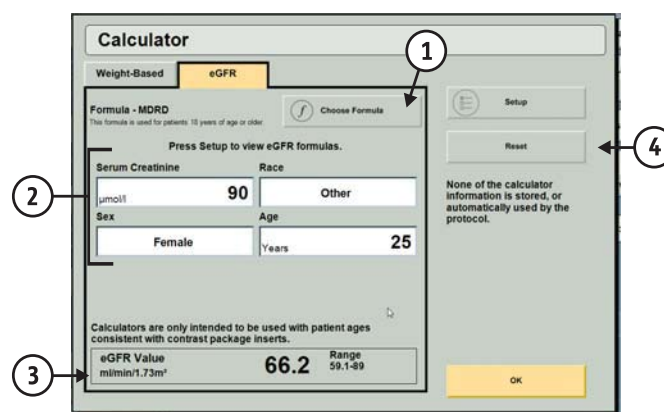

Figure 9 - 8: Using the eGFR Calculator

1. Select **Choose Formula** (1) to choose a formula to use for the calculation.

NOTE: If no formulas have been enabled, a message window will appear alerting the operator to go to Setup and enable an eGFR formula. The user should enable one or more formulas, then return to Step 1 to continue using the eGFR calculator. For information about enabling eGFR formulas, see "[Section 9.2.1.1 - Enabling eGFR Formulas](#)".

2. Press the formula name in the pick list to select it.

- Enter the patient parameters (2) as indicated. Select a parameter, then use the keypad or pick list to input patient parameter.

NOTE: Required parameters will vary based on the selected formula.

- ◆ Serum Creatinine: Enter Serum Creatinine using the keypad. Press Enter to save or Cancel to disregard.
- ◆ Height: Enter the patient's height using the keypad. Press Enter to save or Cancel to disregard.
- ◆ Weight: Enter the patient's weight using the keypad. Press Enter to save or Cancel to disregard.
- ◆ Race: Select from the pick list or select Cancel to disregard.
- ◆ Sex: Select from the pick list or select Cancel to disregard.
- ◆ Age: Enter the age (in years) of the patient using the keypad. Press Enter to save or Cancel to disregard.

- After all required parameters for the selected formula have been defined, the calculated eGFR value will be shown at the bottom of the display (3). If output ranges were enabled, the range will be shown with the calculated eGFR value. If colors were enabled, the eGFR value field color will correspond to the range color.

NOTE: It is recommended that the operator confirm the indicated range against the calculated eGFR value.

NOTE: If no output ranges were defined (See "[Section 9.2.1.2 - Display Output Range Setup - Optional](#)"), only the eGFR value will be shown.

NOTE: To clear all fields, press Reset. (4)

- Click OK to exit the Calculator.

9.3.2 Using the Weight Based Dosing Calculator

NOTE: The calculated Weight Based Dose value is for reference and is not automatically reflected in the programmed protocol. The application of the calculated volume is at the operator's discretion.

NOTE: One or more contrast types must be saved before using the Weight Based Dosing calculator. For more information about saving contrast types, see "[Section 15.4.2 - Contrast Type Setup](#)".

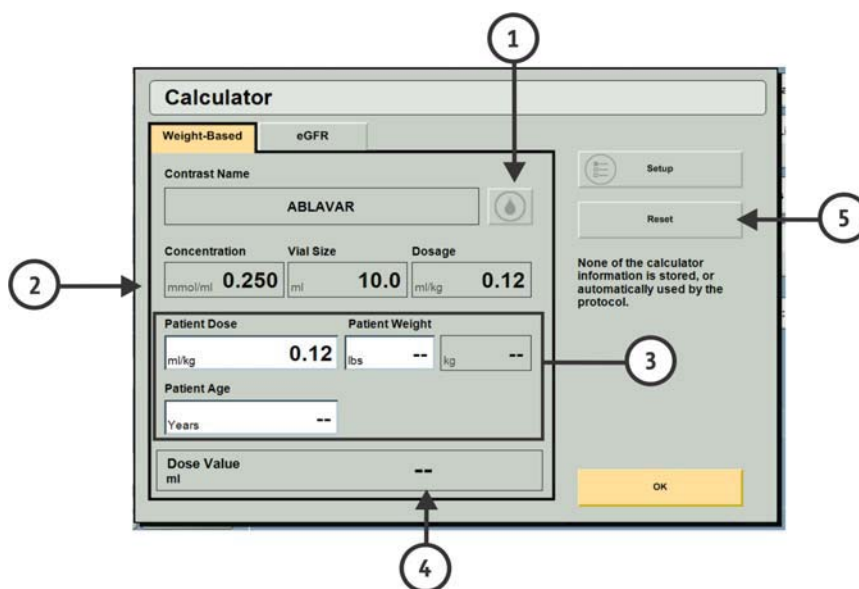

Figure 9 - 9: Using the Weight-Based Dosing (WBD) Calculator

- Select the droplet button (1) to choose the type of contrast from pick list. The concentration, vial size, and labeled dose stored with the selected contrast type will be displayed (2).

2. Select a parameter (3) and add or edit the information using the keypad. Press Enter to save or Cancel to disregard.
 - ◆ Dose: The dose field will automatically populate with the labeled dose stored with the selected contrast type, but may be edited. (Note: If the operator changes the dose, the new dose will be used for the calculation only and will not affect the labeled dose saved with the contrast type.)
 - ◆ Weight: Enter the patient's weight in lbs. or kgs. (Note: The weight units in the editable field will align with the weight unit selected in System Setup. The converted value for the other weight unit will be automatically calculated and displayed below.)
 - ◆ Age: Enter the patient's age in years.
3. After all parameters have been defined, the Weight Based Dosing (WBD) value will be shown at the bottom of the display (4).

NOTE: To clear all fields, press Reset (5).

NOTE: None of the calculator information is stored or automatically used by the protocol.

4. Click OK to exit the Calculator.

10 Protocol Management

10.1 Create or Edit a Protocol

Operators create and edit protocols from the Home Screen.

1. Select an arrow (1) to create or edit a protocol.
2. Choose a phase type from the pick list (2) on the right of the display or choose Delete to remove an existing phase.

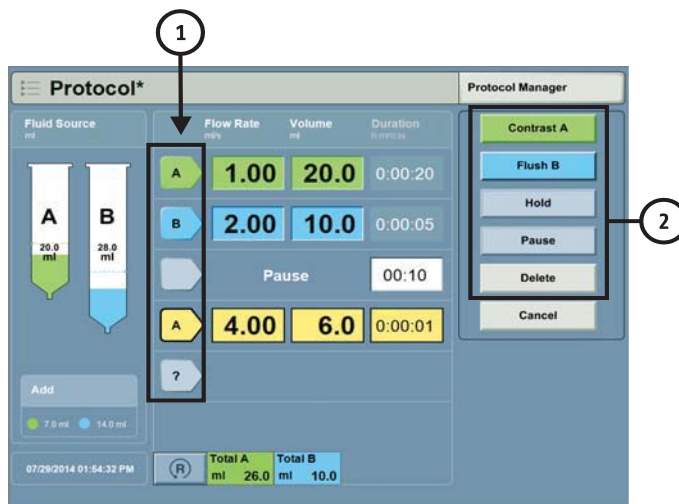

Figure 10 - 1: Select Phase Type

Table 10 - 1: Phase Types

Phase Type	Description
Contrast A	Phase where contrast fluid is delivered from Syringe A.
Flush B	Phase where saline fluid is delivered from Syringe B.
Hold	Phase where the injection is stopped until it is restarted by operator.
Pause	Phase where the injection is stopped for a programmed amount of time. The injection resumes when the defined pause time elapses.

NOTE: An operator may delete phases from a protocol. The delete functionality is only available when editing a protocol with more than one phase.

NOTE: A hold phase cannot be the first phase in a protocol.

3. Select two of the three parameters (3) (See "[Section 15.4.1 - Fluid Delivery Setup Configurable Items](#)" for more information) and enter the values using the keypad(4). The third parameter will be calculated automatically.

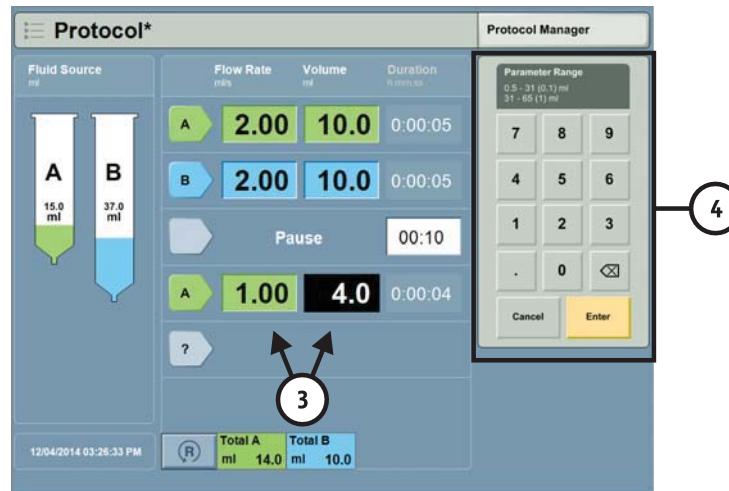

Figure 10 - 2: Enter Parameters

4. Select **Enter** to confirm the entered value or select **Cancel** to disregard.
5. Repeat step 1 to add additional phases.

NOTE: The system provides an on-screen indication and displays how much fluid needs to be added in each syringe if the programmed volume exceeds the amount of volume in the syringe(s). Alternatively, the recalculated values can be accepted on the Insufficient Volume Screen.

NOTE: When modifications have been made to a protocol, an asterisk (*) appears to the right of the protocol name.

NOTE: The protocol can be saved (see "[Section 10.2 - Save a Protocol](#)") and/or it can be used for an injection (see "[Chapter 12 - Arming and Injecting](#)").

6. Optionally, modify the default pressure limit.
 - a. Select **Pressure Limit** (1) from the Home Screen.
 - b. Select a pressure limit from the pick list(2).

NOTE: Ensure that the pressure is set for the patient per facility guidelines. Ensure the proper pressure is set for the catheter and other disposables connected to the system.

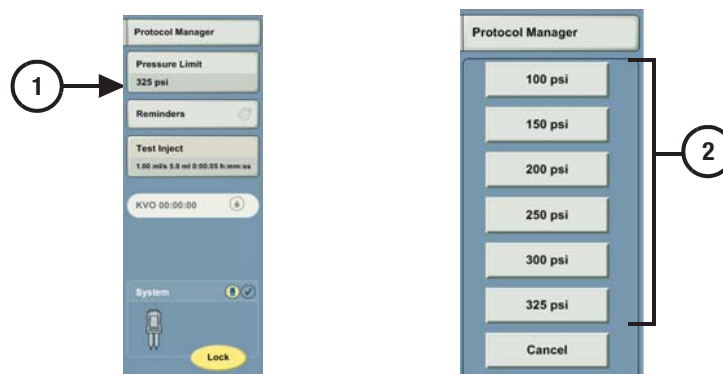

Figure 10 - 3: Selecting Pressure Limit

7. Optionally, set or modify a reminder.

Reminders are alerts that display after an operator-defined amount of time. The system stores reminders as part of the protocol.

a. Select **Reminders** (1) from the Home Screen.

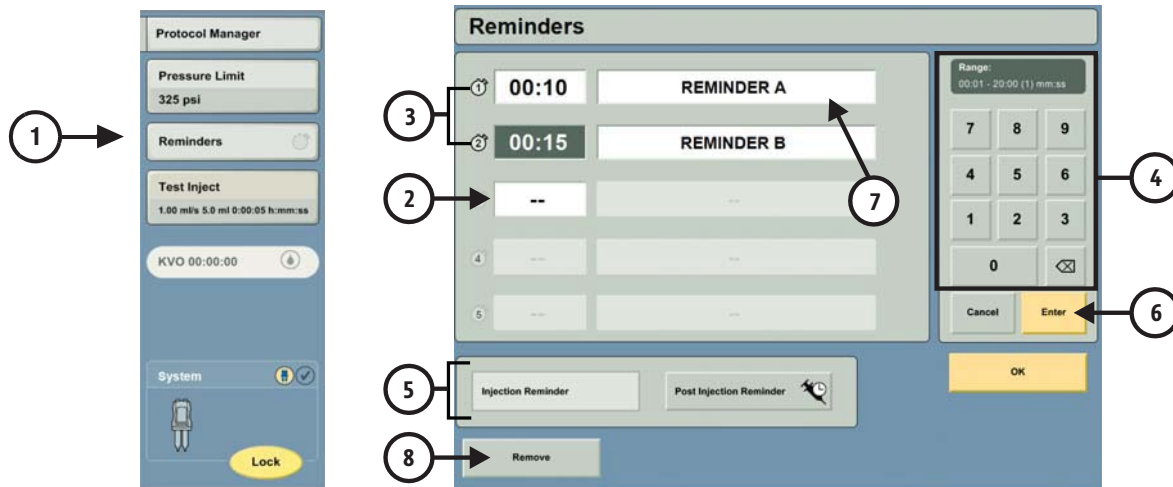

Figure 10 - 4: Enter Reminders

- b. Select an empty reminder slot (2) to enter new or additional reminders or select an existing reminder (3) to modify the parameter.
 - c. Enter the time for the reminder in minutes and seconds using the keypad (4).
 - d. Select the type of reminder (5), then select **Enter** (6).
 - ◆ Injection Reminder: Displays after the operator-defined time has elapsed since initiating the injection.
 - ◆ Post Injection Reminder: Counts down from when the protocol completes instead of counting up from the protocol initiation like the standard reminder. Displays after the operator-defined time has elapsed after an injection has completed. Post-injection reminders begin counting once the injection is complete and will not display if the Injection Completed screen is exited before the operator-defined amount of time has elapsed since the completion of the injection.
 - e. Optionally, select the description field (7). A keyboard will popup on the screen and the operator can add a brief description that will appear on the reminder dialog. Type the description and press **Enter**.
 - f. Optionally, select an existing reminder, then select **Remove** (8) to delete it.
 - g. Select **OK** to save changes and return to the Home Screen.
8. Optionally, modify parameters for a test injection.

A test injection is defined separately from the protocol. The test injection parameters are defined via the **Test Inject** button on the Home Screen.

The test injection can be initiated by pressing the **Test Inject** button on the injector head after the I Checked for Air confirmation is completed and before the start of the protocol. The injector head must be tilted downward to initiate a test injection.

To define or modify the Test Inject parameters:

- a. Select **Test Inject** (1).

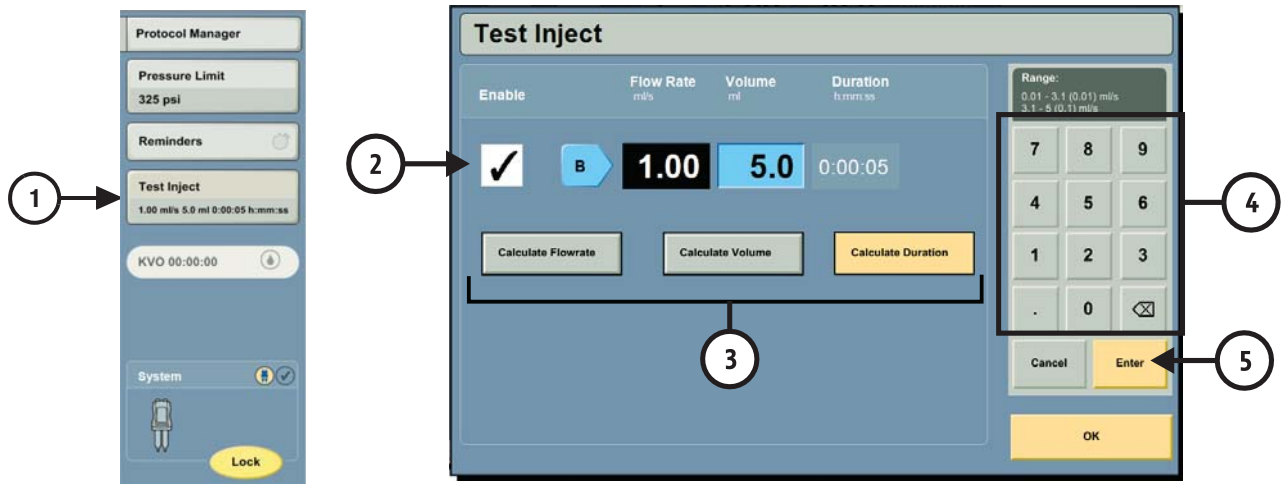

Figure 10 - 5: Edit Test Inject Parameters

- b. Check the Enable box (2) to enable the test injection function.
- c. Select the parameter (3) to be automatically calculated.
- d. Enter the value for the two remaining parameters using the keypad (4) and select **Enter** (5).
- e. Select **OK** to confirm and save.

10.2 Save a Protocol

Operators can save protocols that have been created or edited on the Home screen.

NOTE: Unique protocol names are required within the same region.

1. Select **Protocol Manager** from the Home Screen.
2. Under *Region*, select the folder in which to store the protocol.
3. Under *Preview*, select **Store in <Region>**.
4. Enter a name for the protocol and select **Enter** to save.

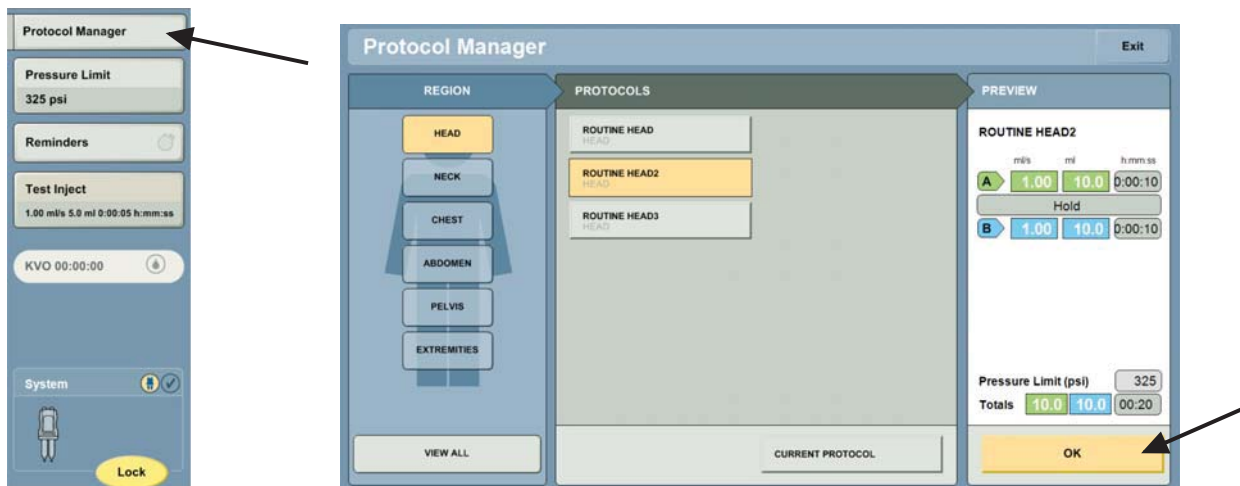

Figure 10 - 6: Save a Protocol

10.3 Recall a Saved Protocol

1. Select **Protocol Manager** from the Home Screen.
2. Select the desired region or select **View All** (1).
3. Select the protocol name (2).
4. Select **OK** (3). The Home screen displays the selected protocol.

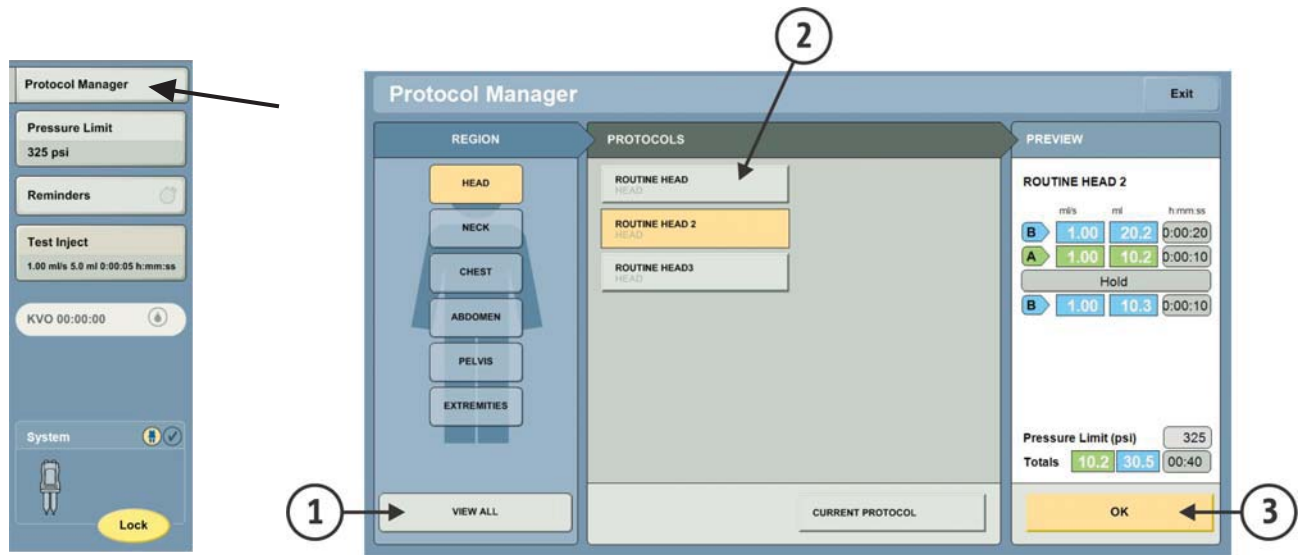

Figure 10 - 7: Recall Protocol

To edit the protocol, see "[Section 10.1 - Create or Edit a Protocol](#)". To use the protocol for an injection, see "[Chapter 12 - Arming and Injecting](#)".



11 Preparing for Injection

WARNING

Blood Vessel Hazard - Serious patient injury or death may result.

- ◆ Ensure that the programmed flow rate meets facility guidelines.

Air Embolism Hazard - Serious patient injury or death may result.

- ◆ Expel all trapped air from the syringe(s), connectors, tubing, and catheter-over-needle before connecting the system to the patient. Carefully read the instructions for loading and the use of the FluiDots indicators (where applicable) to reduce the chance of air embolism.
- ◆ The presence of rounded FluiDots indicators does not indicate the total absence of air bubbles in the syringe tip. FluiDots indicators must be viewed in a properly illuminated environment with a light source behind the operator providing enough light to permit easy viewing.
- ◆ To minimize air embolization risks, ensure that one operator is designated the responsibility of filling the syringe(s). Do not change operators during the procedure. If an operator change must occur, ensure that the new operator verifies that the fluid path is purged of air.
- ◆ To minimize the possibility of inadvertent aspiration and injection, ensure the patient is disconnected from the injector when using the forward and reverse piston controls.

Biological Contamination Hazard - Serious patient and/or worker injury or death may result.

- ◆ Re-using fluid containers for more than one procedure may result in biological contamination. Discard contrast and saline containers after filling syringes for a single procedure.
- ◆ Properly discard syringes and connector tubing after use (refer to label for specifics) or if there is any possibility that contamination may have occurred.
- ◆ Bayer syringes and tubing sets are for single use only.
- ◆ The System is not intended to deliver contrast agents and/or saline to more than one patient from the same contrast or saline container.
- ◆ Use of the system is intended to be consistent with contrast package labeling.

Environmental Contamination Hazard - Serious patient or worker injury or death may result.

- ◆ Follow aseptic technique when handling syringe and connector tubing components. Specifically, maintain sterility of all syringe and connector tube components.
- ◆ Do not disassemble any syringe or connector tubing components. Do not remove the plunger from the syringe.
- ◆ Visually inspect contents and package before each use. Do not use if sterile package is opened or damaged.

Bacterial Contamination Hazard - Serious patient and/or worker injury or death may result.

- ◆ Syringes are not intended to be used as storage containers. Do not use syringes to store fluids. Use filled syringes immediately.

Mechanical Hazard - Patient injury could result from fluid leaks or tubing ruptures during an injection.

- ◆ Use only Bayer approved syringes and connector tubing.
- ◆ Use catheters and connectors with pressure ratings compatible with this system.
- ◆ Ensure that the fluid path is open and do not use syringes and tubing rated below 350psi (2410 kPa). An occlusion in the fluid path and/or use of syringes or tubing rated below 350 psi (2410 kPa) may result in leaks or ruptures.
- ◆ Patient injury and/or catheter damage may result from using tubing set that is too short. Operator must consider tubing length and stretch limitations when moving the injector or the patient

Patient injury could result from movement of the scan room unit (injector) after the patient is connected to the fluid path.

- ◆ Do not move the Injector with the patient connected.
- ◆ Lock the casters at the base of the unit to prevent unintended movement.

11.1 Control Room Preparation

11.1.1 Prepare Injection Protocol

A protocol must be set and locked prior to installing syringes in order to use any enabled automatic syringe installation features.

1. Set the protocol.
 - a. To recall a protocol, see ["Section 10.3 - Recall a Saved Protocol"](#).
 - b. To create or edit a protocol, see ["Section 10.1 - Create or Edit a Protocol"](#).
2. Select **Lock** on the display.

NOTE: The icon on the display changes to **Arm**, and the injector head **Protocol Lock** indicator illuminates.

11.2 Scan Room Preparation

The disposables tray is designed to fit in the handle of the injector for your convenience. If desired, place the tray in the handle as shown below while installing the syringe and connector tubing or to collect priming waste.

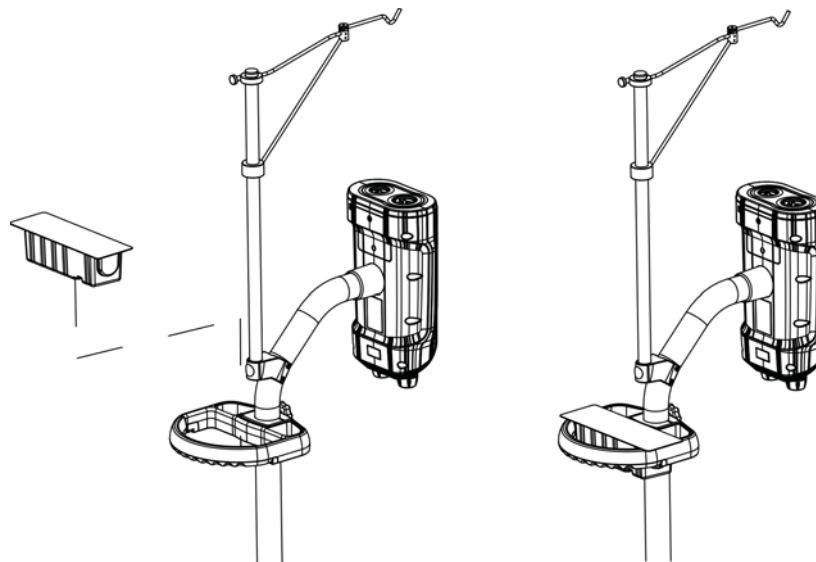

11.2.1 Installing a Syringe

NOTICE

Mechanical Hazard - Equipment damage may result.

- ◆ Do not install syringes and connector tube with excessive force.

1. Remove the syringes from packaging.
2. Install a new syringe on the injector head by inserting it quickly and firmly in one motion until it is securely in place and an audible click is heard. Remove the dust covers from the tip of each syringe.

NOTE: Syringe A (65 mL) is the contrast syringe and Syringe B (115 mL) is the saline syringe.

3. With the Auto Advance feature, the piston automatically advances and engages the syringe plunger and then advances it to the full forward (0 mL) position. The **Fill A** and **Fill B** button will blink when Auto Advance is complete for the corresponding syringe.
 - ◆ If Auto Advance is configured to be OFF, manually advance the plunger to the end of the syringe using the forward piston control on the injector head or the manual knobs.

11.2.2 Filling a Syringe: Automatically or Manually

NOTE: If using a Female/Female Adapter (FFA) to load fluid from a pre-filled syringe, attach the FFA onto the tip of the syringe instead of a spike for the following steps. (The FFA may be purchased separately. The catalog number for this item is FFA 50.)

NOTE: The small spike should be installed on Syringe A (contrast syringe). The large spike should be installed on Syringe B (saline syringe).

NOTE: If using Auto Fill to fill a syringe, ensure a protocol has been selected and locked prior to filling the syringes.

1. Remove the spike from the packaging. Remove the dust cover from the luer end of the spike.
2. Install the spike on the corresponding syringe, then insert the spike into the correct fluid source. Refer to the fluid manufacturer's instructions for use and/or package insert.

NOTE: The system has the capability of supporting up to a 150mL bag of saline and a single patient dose contrast bottle for hands-free fluid preparation.

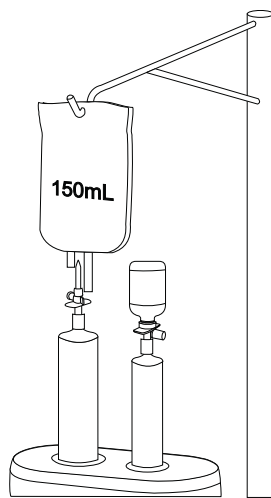

Figure 11 - 1: Hands-Free Fluid Preparation

3. To **automatically** fill the syringe:
 - a. Press the Fill button corresponding to the syringe to be filled. The volume indicator on the injector head displays the amount of fluid that needs to be loaded to support the displayed protocol, including the amount necessary to prime the patient tubing.
 - b. Press the +/- buttons to increase or decrease the amount of volume to be loaded.
 - c. Press the Fill button corresponding to the syringe to be filled again to fill the syringe to the displayed volume. Wait 3-5 seconds for Auto Fill to complete to avoid fluid spills from spikes.

NOTE: The Auto Fill volume for Syringe B includes the programmed injection volume, volume to run KVO for 30 minutes (if KVO is enabled), prime volume if Syringe B is configured to be used for priming, and volume to perform a test injection (if Test Inject is enabled).

NOTE: Auto Fill disables after 10 seconds of inactivity.

NOTE: The system draws in the configured Auto Load Purge Volume and then expels this volume. The Auto Load Purge volume can be set to 10mL, 5mL, or 2mL. (Instructions for setting the Auto Load Purge volume are in "[Section 15.4 - Fluid Delivery Setup](#)".)

4. To **manually** fill the syringe:

- a. Press the Enable Piston Control button to activate the piston controls and use the reverse piston control to fill the syringe with the desired amount of fluid. Alternatively, use the manual knob.

NOTE: Enable Piston Control disables after 10 seconds of inactivity.

NOTE: If protocol volume is greater than fill volume, an insufficient volume communication will display when arming the injector.

5. Ensure the fluid path is free from excess air.

NOTE: If bubbles appear in the syringe, DO NOT hit the syringe to remove them. Reverse the plunger 3 - 5 mL, then rock the injector head on the pivot with the syringe pointed up to gather and accumulate the small bubbles. Expel the remaining air.

6. Remove the spike and discard the fluid source containers and spikes.

7. Connect the disposable connector tube as outlined in "[Section 11.2.3 - Attach and Prime the Tubing](#)".

11.2.3 Attach and Prime the Tubing

NOTICE

Mechanical Hazard - Equipment damage may result.

- ◆ Do not install syringes and connector tube with excessive force.

1. Remove the connector tube from the package. Remove the dust covers on the luer fittings.

2. Ensure that all air is purged from the syringes.

NOTE: If bubbles appear in the syringe, DO NOT hit the syringe to remove them. Reverse the plunger 3 - 5 mL, then rock the injector head on the pivot with the syringe pointed up to gather and accumulate the small bubbles. Expel the remaining air.

3. Attach the connector tube to the syringes as shown. Do not install with excessive force.

4. Ensure that the connector luer fitting is secured to the tips of the syringes. Verify that the tubing is not kinked or obstructed.

5. Prime the tubing with fluid manually or using the Prime function:

a. Prime Function

- i. Press the **Prime** button on the injector head.



b. Piston Control Prime

- i. Press the Enable Piston Control button and use the piston controls to prime the tubing.

c. Manual Prime

- i. Turn the manual knob to advance the piston to prime the tubing.

NOTE: Use the appropriate fluid to prime the tubing. Syringe A is the contrast syringe and Syringe B is the saline syringe.

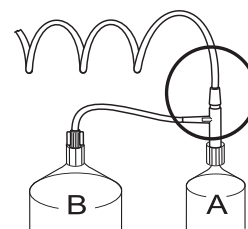

6. Ensure the fluid path is free from excess air.

NOTE: If required, turn the manual knobs or repeat the priming steps above to advance fluid and remove any remaining air.

7. Confirm that the fluid path has been examined and is free from excess air by pressing the I Checked for Air Confirmation button on the injector head.

11.2.4 Connect the Tubing to Patient

WARNINGS

Air Embolism Hazard - Serious patient injury or death may result.

- ◆ I Checked for Air must be completed and confirmed before connecting the tubing to the patient.

CAUTIONS

Do not move the injector with the patient connected. Minor or moderate patient and/or worker injury may result.

1. Position the injector near the scanner table.
2. Rotate the injector head downward.
3. Connect the tubing to the patient.



12 Arming and Injecting

NOTE: Verify that the protocol is correct prior to locking the protocol.

12.1 Add Volume Indicator

Whenever the total volume programmed to be injected is greater than the volume remaining in the syringes, the Home Screen provides on-screen Add Volume indicators to communicate how much fluid should be added to perform the protocol.

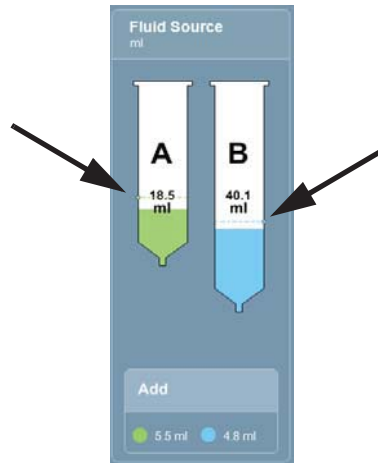

Figure 12 - 1: Add Volume Indicators

NOTE: The operator can resolve this condition prior to arming the injector by adding more fluid to the syringe or modifying the protocol. If the operator does not correct the insufficient volume prior to priming, the Insufficient Volume Message is displayed and the operator can choose to accept the modified protocol changes displayed on the message window.

12.2 Arming the Injector

The system can be armed from the control room or the scan room.

NOTE: The injector head must be in the downward position prior to arming. The system prevents arming if the head is in the upright position.

12.2.1 Arming from the Control Room

1. Select **Arm** on the display.

NOTE: If the last piston movement was a reverse movement or if a syringe required by the protocol is not present, the system will not permit arming and will communicate this to the operator. The message in Figure 12 - 2: Arming Prevented Communication appears, the Attention Indicator flashes amber, and the Volume Indicators display "--".

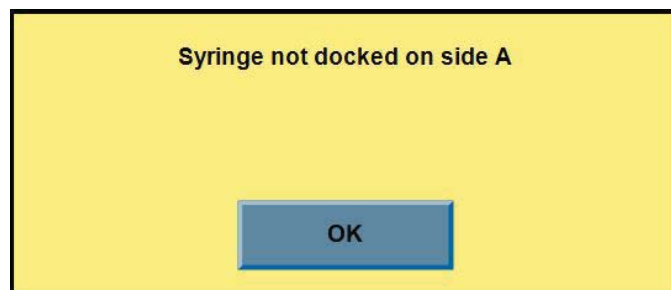
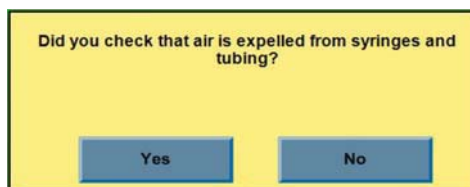

Figure 12 - 2: Arming Prevented Communication

2. After examining the fluid path to determine it is free from excess air, perform the I Checked for Air Confirmation:

**Figure 12 - 3: I Checked for Air Confirmation**

- a. Select **Yes** to acknowledge that the operator has examined the syringes and connector tubing and has determined that all air has been expelled.

NOTE: When the operator selects **Yes**, the I Checked for Air icon illuminates on the display and the I Checked for Air Confirmation button illuminates on the injector head.

- b. Select **No** if the operator has not checked that all air has been expelled from the syringe and tubing or if air is observed while checking. The system does not arm.

NOTE: The system monitors the syringe presence and piston movement after the I Checked for Air has been confirmed. If the syringe is removed or the piston is reversed, the system resets the I Checked for Air confirmation.

3. If the operator did not correct the Add Volume Indicator prior to arming, the Insufficient Volume message is displayed.

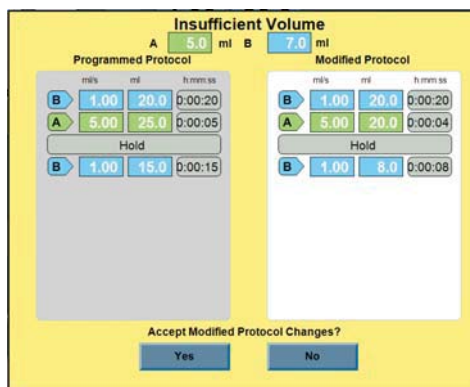
**Figure 12 - 4: Insufficient Volume Message**

The system generates a modified protocol based on the available Volume Remaining.

- a. Select **Yes** to accept the system-modified protocol. The system continues with the arming process. Go to ["Section 12.4 - Initiating an Injection"](#).
- b. Select **No** to reject the system-modified protocol. The system does not arm.

The system remains armed until one of the following conditions are met,

- ◆ An operator selects **Disarm** on the display.
- ◆ An operator presses the **Abort** button on the injector head or the Pod.
- ◆ An operator activates any injector head controls other than **Start/Hold** or **KVO**.
- ◆ The injector head is moved to the upright position.
- ◆ An injection has completed.



NOTE: When armed, the injector head **Arm** button illuminates, the injector head Injector Status Lights blink, and the display shows a **Disarm** icon.

12.2.2 Arming from the Scan Room

1. Press the I Checked for Air Confirmation button on the injector head to acknowledge that the operator has confirmed that all air has been expelled from the syringe and tubing.

NOTE: If the last piston movement was a reverse movement or if a syringe required by the protocol is not present, the system does not permit arming and communicates this to the operator. The Attention Indicator blinks amber and the Volume Indicators displays "--".

NOTE: On the display, the I Checked for Air icon illuminates and on the injector head, I Checked For Air Confirmation button illuminates.

2. Orient the injector head in the downward position.
3. Start KVO (Optional).
4. Press the **Arm** button on the injector head.
 - a. If a protocol has not been locked, the Attention icon blinks and the system does not arm.
 - b. If the I Checked for Air has not been confirmed, the I Checked For Air Confirmation button blinks.
 - c. If an insufficient volume condition exists, the Attention Indicator blinks amber and the Volume Indicators display "--".
 - i. Press the **Arm** button on the display to accept the system modified protocol shown on the display, or
 - ii. Wait until Volume indicator stops flashing and address insufficient volume by adding more fluid to the syringe, modifying the protocol.

The system remains armed until one of the following conditions are met,

- ◆ An operator selects **Disarm** on the display.
- ◆ An operator presses the **Abort** button on the injector head or the Pod.
- ◆ An operator activates any injector head controls other than **Start/Hold** or **KVO**.
- ◆ The injector head is moved to the upright position.
- ◆ An injection has completed.

NOTE: The Icon changes to indicate **Disarm**, the injector head **Arm** button illuminates, and the Injector Status Lights blink.

12.2.2.1 Initiating a Test Injection (Optional)

1. Following the I Checked for Air Confirmation, press the **Test Inject** button on the injector head to initiate a test injection.



NOTE: A test injection can only be initiated from the injector head. It is not part of the programmed protocol.

NOTE: A test injection can be used to see if the catheter is properly placed.

NOTE: To configure Test Inject parameters, refer to ["page 10 - 39"](#)

12.3 Starting KVO (Optional)

If enabled, KVO can be initiated prior to initiating the injection. (For information about setting the KVO interval or disabling KVO, see ["Section 15.4.1 - Fluid Delivery Setup Configurable Items"](#)) It will function during Pause and/or Hold periods. KVO will resume post-injection until no fluid remains in syringe B or until KVO is stopped by the operator.

If the head is oriented upwards, I Checked for Air has not been confirmed, or there is insufficient volume, the system will prevent the start of KVO. This is indicated by the Attention Indicator flashing amber and the Volume Indicators display "--".

- Following the I Checked for Air Confirmation, select the **KVO** button to initiate KVO.



- KVO may be stopped at any time by selecting the **KVO** button after KVO is initiated (illuminated in blue) or by pressing any injector head control button. This will also disarm the system and terminate any injection in progress.

NOTE: Other actions that disarm the injector, such as syringe removal, pressing the **Disarm** button, and injection stall will also stop KVO.

NOTE: If an occlusion occurs during KVO, the system will detect the condition after 4 or less KVO boluses fail to be delivered. (The occlusion will be detected after 1 minute or less if the KVO interval is set to 15 seconds or after 5 minutes or less if the KVO interval is set to 75 seconds.) Refer to "[Section 15.4 - Fluid Delivery Setup](#)" for information about setting KVO intervals.

12.4 Initiating an Injection

NOTE: It is recommended that the operator stay by the patient's side at the beginning of the injection.

- Press **Start/Hold** on the injector head, Pod, or hand switch.

NOTE: See "[Chapter 7 - System Lights and Indicators](#)" for a description of how the system lights function while armed, injecting, and/or during a hold.

NOTE: If the protocol contains a Hold phase, the system holds the injection until the operator presses **Start/Hold** on the injector head, Pod, or hand switch to resume the protocol.

12.5 Operator Initiated Hold

If the operator presses **Start/Hold** during an injection phase, the system holds the injection until the operator presses **Start/Hold** on the injector head, Pod, or hand switch to resume the protocol.

NOTE: If an operator initiates a hold, the Reminder elapsed time is halted. The Reminder elapsed time starts when the operator re-initiates the protocol.

12.6 Aborting an Injection

At any time, press the **Abort** button on the Pod or injector head to abort the injection. An injection will also abort if the injector head is moved to the upright position during an injection.

12.7 Viewing Injection Progress

During an injection, the system displays the following:

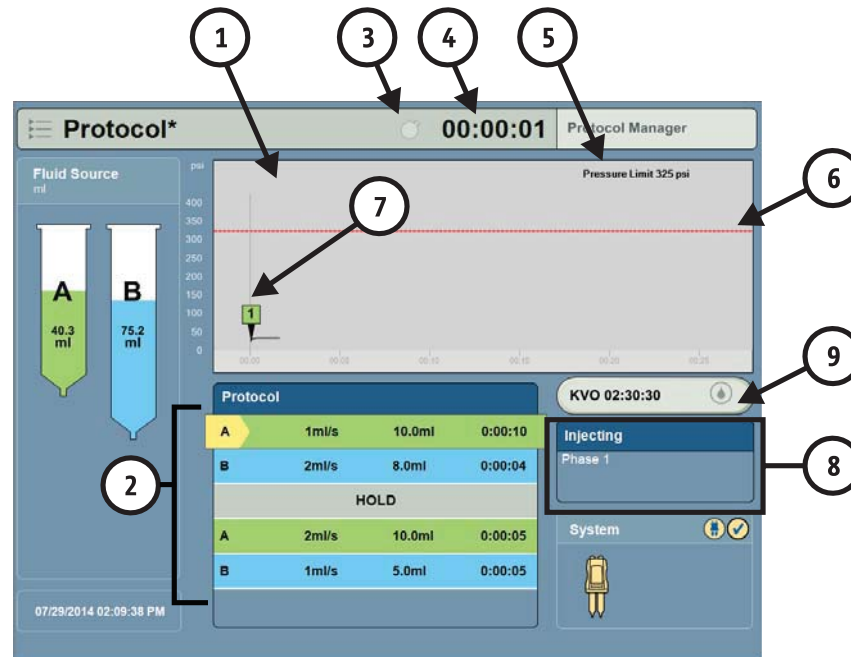

Figure 12 - 5: Injection Views

1	Pressure Graph	The graph shows the pressure sensed by the system during an injection.
2	Phase View	The system highlights each phase as it starts.
3	Reminders	Indicates the number of set reminders.
4	Elapsed Time	Shows the duration of the injection. ♦ If a test injection is initiated, the elapsed time begins after the test injection completes.
5	Pressure Limit	Shows the programmed pressure limit.
6	Pressure Limit Line	Displays the programmed pressure limit on the pressure graph.
7	Indicators of Start of Phase	Shows the start of each phase.
8	Injection Information	Displays the current phase information during the injection.
9	KVO Button	Illuminated blue to indicate when KVO is activated. Press at any time during the injection to end KVO.

NOTE: If the injection is aborted, all remaining reminders are ignored.

NOTE: Elapsed time continues during a Hold phase.

NOTE: A blinking Pause symbol will appear on the Pressure Graph and the Injector icon will blink during either an Operator Initiated Hold or a Programmed Hold.

12.8 Reminders

A Reminder dialog will display after the programmed time for the Reminder has elapsed.

NOTE: If a Test Inject phase is performed, the reminder elapsed time begins with the start of the first phase after the Test Inject. After the test injection, the system holds the injection until the operator presses **Start/Hold** on the injector head.

NOTE: If a reminder is set, the operator is provided a communication once the elapsed time equals the reminder. The reminder dialog disappears from the screen when the operator acknowledges the communication or the next reminder dialog is activated.

1. Press **OK** to close the reminder dialog.

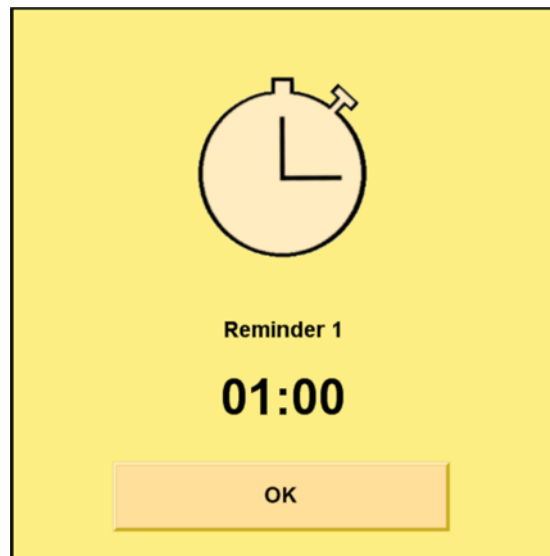

Figure 12 - 6: Reminder Dialog

13 Completing an Injection

13.1 Injection Complete

When an injection completes:

- ◆ The Injection Completed screen displays a summary of the injection and the total fluid delivered.
- ◆ The elapsed time of the injection continues to increment until an operator exits the Injection Completed screen.
- ◆ KVO, if activated (the KVO button will be illuminated blue), continues to dispense small boluses of saline until the operator stops KVO or until no fluid remains in Syringe B.

NOTE: Any remaining reminders will display as they are triggered.



Figure 13 - 1: Injection Complete Summary

	Name	Description
1	Procedure Data	Displays operator configured parameters at the procedural level.
2	Protocol Summary	Displays details of the completed protocol.
3	Summary/Graph	Allows the operator to toggle between Summary view and Graphical view.
4	Same Patient/New Patient	Allows the operator to select if the next injection will be for the same patient or a different patient.

NOTE: Elapsed time continues while this screen is displayed.

1. Select the **Graph** button to view a graphical representations of the injection.

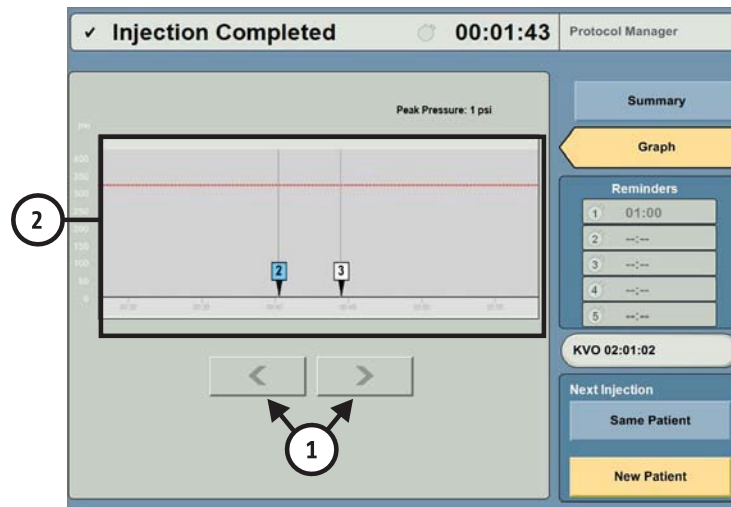

Figure 13 - 2: Injection Complete - Graph

2. Select the left or right arrow (1) to scroll through the injection history. (If the entire injection history fits within the graph, no arrows will appear.)
3. A graphical representation (2) of the phases and pressure limits of the completed injection is displayed until the Injection Complete screen is exited.

NOTE: Elapsed time continues while this screen is displayed.

13.2 Injection Aborted

If the injection was halted, the Injection Aborted screen displays,

- ◆ The reason why the injection aborted at the top of the screen. (1)
- ◆ The procedure data for the aborted injection. (2)
- ◆ Information for how much of the protocol was completed. (3)

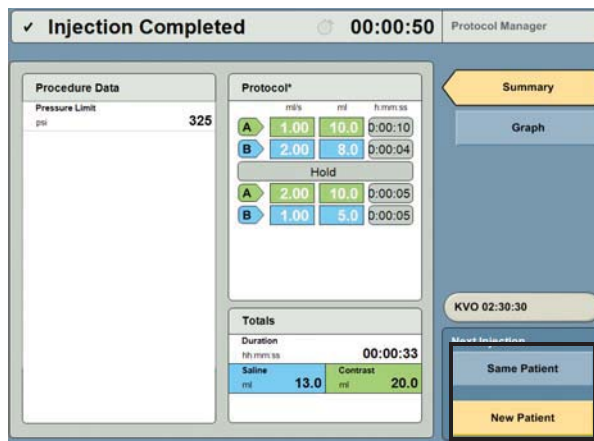

Figure 13 - 3: Injection Complete - Injection Aborted

13.3 Exiting Injection Complete

13.3.1 Conducting Another Injection

NOTE: Depending on how Fluid Delivery Setup is configured, the protocol may reset after the injection. The default setting is for the system to keep the previous protocol for the next injection.



1. Select **Same Patient**.
 - a. The operator is returned to the Home screen.
 - b. See ["Section 10.1 - Create or Edit a Protocol"](#) to create or edit a protocol, or repeat the steps in ["Section 12.2 - Arming the Injector"](#).
2. Select **New Patient**.
 - a. The following message will display. Disconnect the patient, remove syringes from the injector, then press OK.

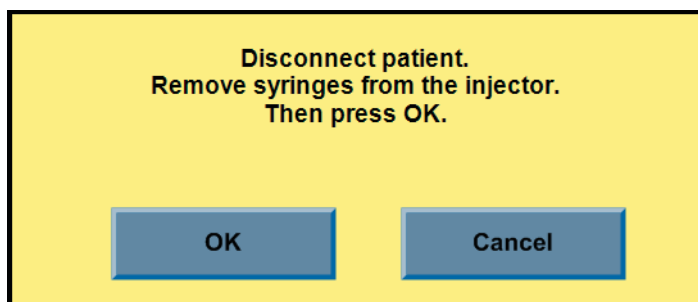

- b. The operator is returned to the Home screen.
 - c. See ["Chapter 11 - Preparing for Injection"](#) for further instructions.



14 Removing Disposable Syringes and Connector Tube

14.1 Removing Disposable Syringes and Connector Tube

 **WARNING**

Biological Contamination Hazard - Serious patient and/or worker injury or death may result.

- ◆ Properly discard syringes and connector tube after single use or if contamination may have occurred during setup or use.

1. Disconnect the disposable connector tube set from the catheter.

NOTE: The disposable connector tube set does not need to be disconnected from the syringe.

2. Remove the syringe by twisting a few degrees counterclockwise and pulling out.

NOTE: Once the syringe has been removed, the piston automatically retracts to the start position (if enabled).

3. Discard all used syringes and connector tube per facility regulations.



15 Advanced Configurations

15.1 System Setup

System Setup enables the operator to configure settings that affect operation of the overall system.

1. From the launch menu, select **Setup**, then select **System Setup**.

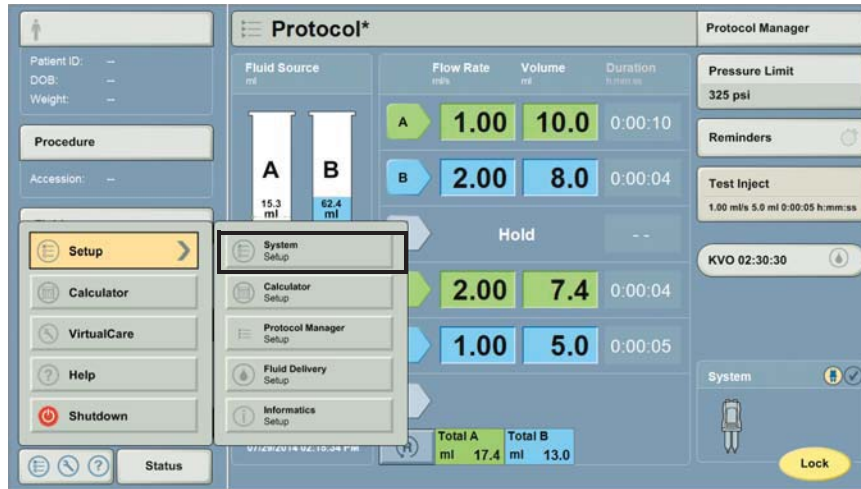

Figure 15 - 1: Setup Categories (System Setup)

2. Select a System Setup option or toggle to the next screen for additional options.

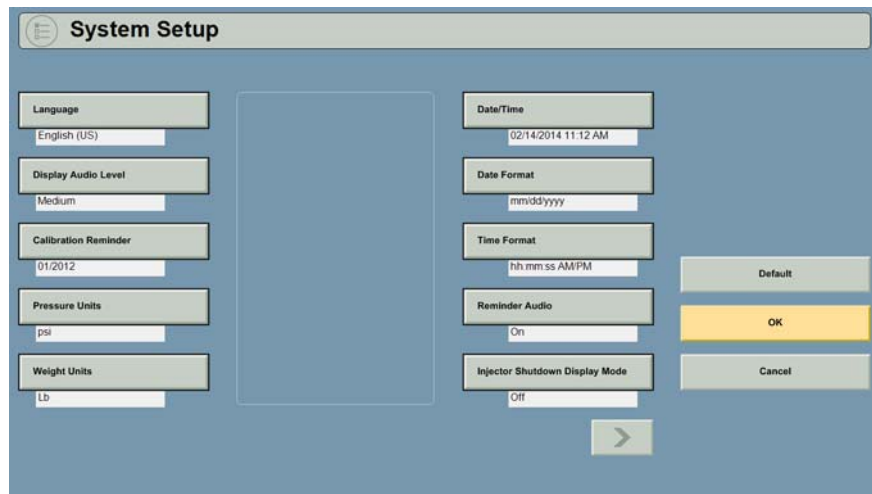

Figure 15 - 2: Setup Screen (System Setup)

- Set the parameter for the selected option.

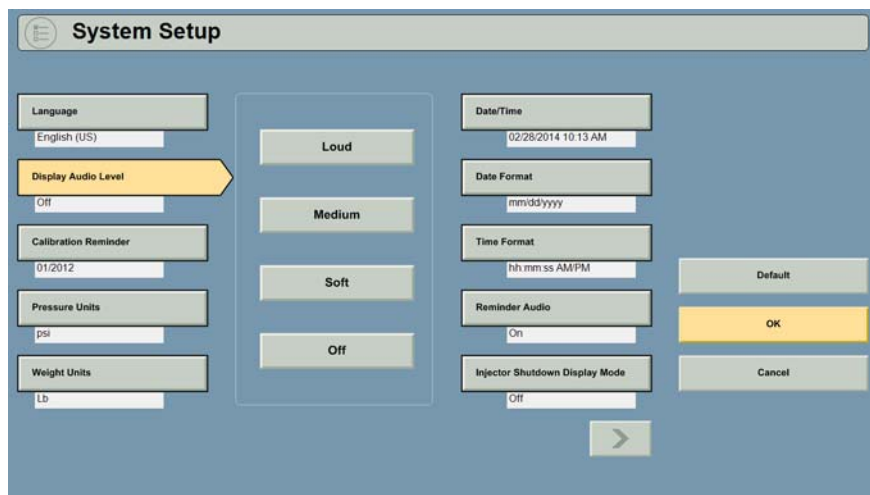

Figure 15 - 3: Option Parameters for Display Audio Level - System Setup

- Select **OK**.
- Select **Yes** to confirm and save the changes.

15.1.1 System Setup Configurable Items

Configurable Item	Description
Language	Sets the display language.
Display Audio Level	Sets the audio volume for the display to loud, medium, soft or off.
Calibration Reminder	Set the date (month and year) for a calibration reminder.
Pressure Units	Sets the pressure measurement to PSI or kPa.
Weight Units	Sets the weight units to lbs. or kg.
Date/Time	Sets the system date and time.
Date Format	Sets the date format.
Time Format	Sets the time format.
Reminder Audio	Enables or disables the reminder audio.
Injector Shutdown Display Mode	Sets display mode during Injector Shutdown to on or off.
Dosing Units	Sets the dosing units to mmol/kg or mL/kg.
eGFR Calculator	Enables or disables the eGFR calculator.
Weight Based Dosing Calculator	Enables or disables the Weight Based Dosing calculator.

15.2 Calculator Setup

Calculator Setup is only an option from the Launch Menu when one or more calculators are enabled. See ["Section 9.2 - Calculator Setup"](#) for more information.

15.3 Protocol Manager Setup

Protocol Manager Setup enables the operator to manage the organization and display of protocols that are stored in the Protocol Manager. To create or edit a protocol, refer to "[Section 10.1 - Create or Edit a Protocol](#)".

1. From the launch menu, select **Setup**.
2. Select **Protocol Manager Setup**.

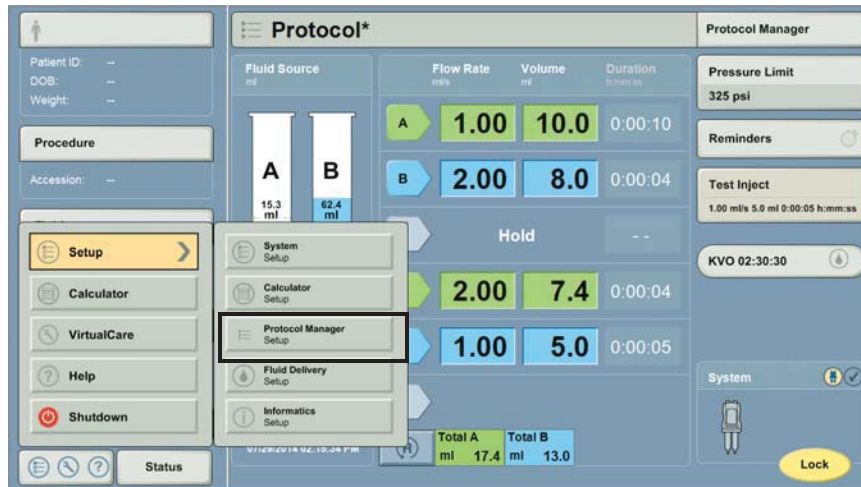

Figure 15 - 4: Setup Categories (Protocol Manager Setup)

15.3.1 Delete a Protocol

1. From the Protocol Manager Setup screen, select the desired region.
2. Select the protocol name.
3. Select **Delete**.
4. Select **Yes** on the confirmation window to delete the protocol.

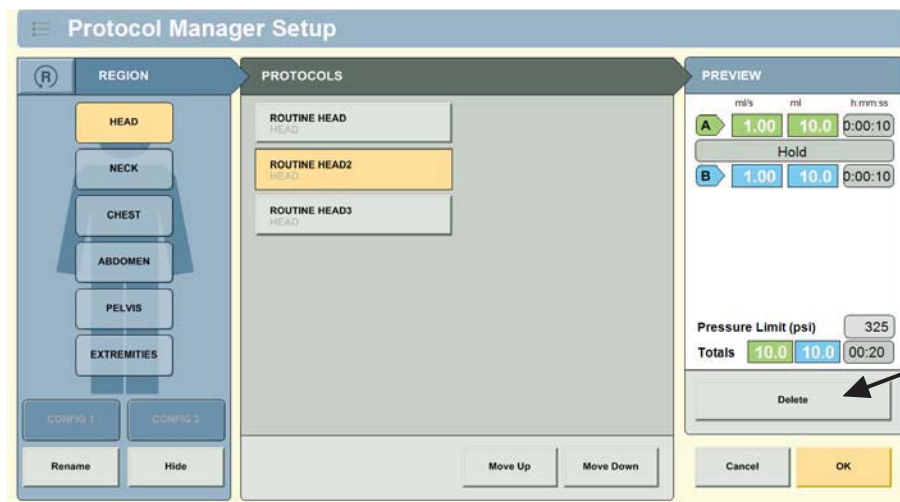

Figure 15 - 5: Delete a Protocol

15.3.2 Rearrange Protocol List

1. From the Protocol Manager Setup screen, select the protocol name.
2. Select **Move Up** or **Move Down**.

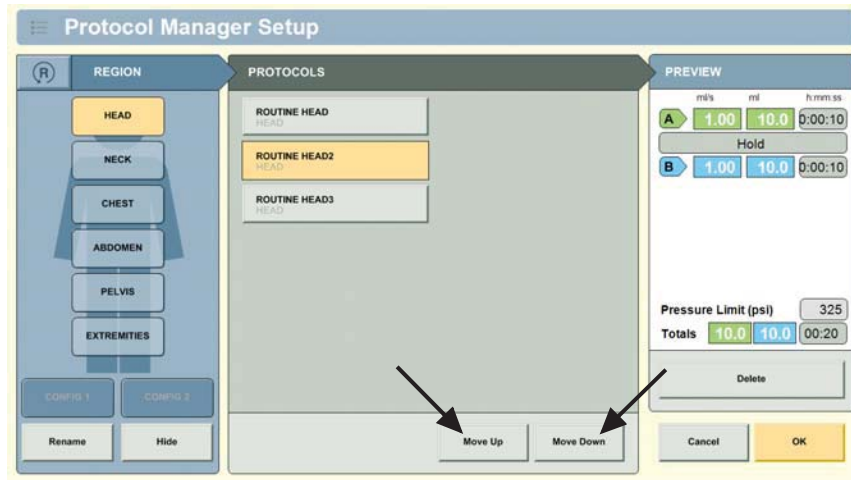

Figure 15 - 6: Rearrange Protocol List

15.3.3 Hide/Show a Region

1. From the Protocol Manager Setup screen, select the desired region.
2. Select **HIDE** to hide a region and select **SHOW** to display a hidden region.



Figure 15 - 7: Hide a Region

15.3.4 Rename a Region

1. From the Protocol Manager Setup screen, select the desired region.
2. Select **RENAME**.

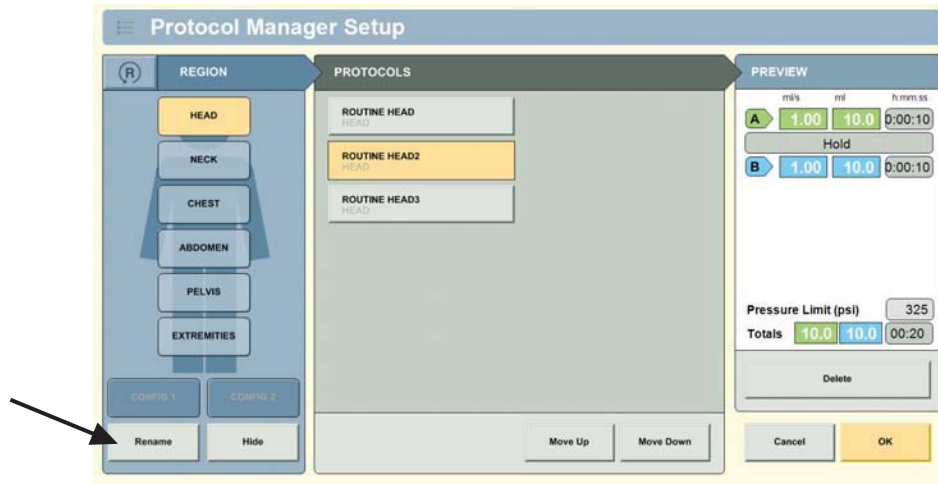

Figure 15 - 8: Rename a Region

3. Enter the name using the keyboard that pops up, and select **Enter**.
4. Select **OK**, then select **Yes** on the confirmation window to save changes.

15.4 Fluid Delivery Setup

Fluid Delivery Setup enables the operator to configure settings that affect the operation of the fluid delivery system specifically.

1. From the launch menu, select **Setup**.
2. Select **Fluid Delivery Setup**.

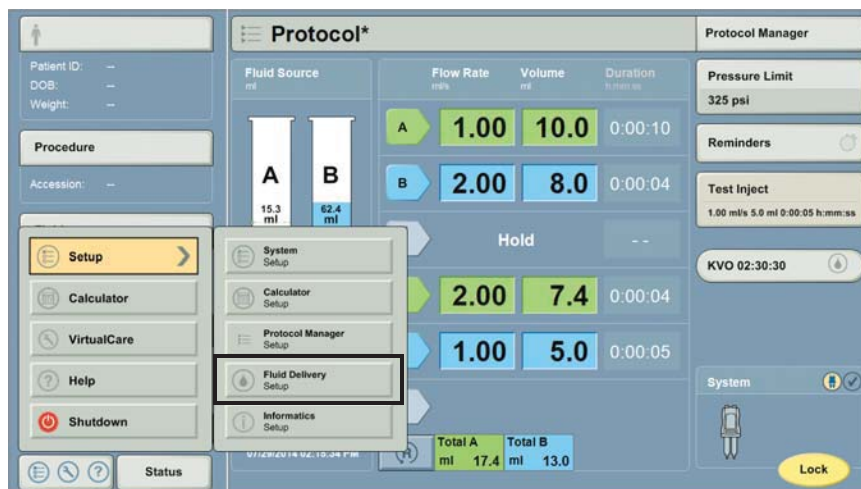

Figure 15 - 9: Setup Categories (Fluid Delivery Setup)

3. Select a Fluid Delivery Setup option (1) or toggle to the next screen for additional options (2).

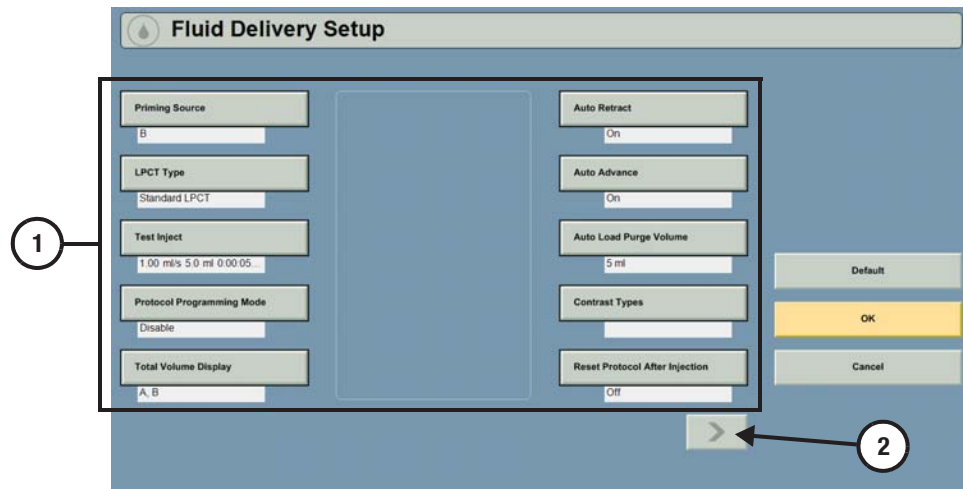

Figure 15 - 10: Setup Screen (Fluid Delivery Setup)

4. Set the parameter for the selected option.



Figure 15 - 11: Option Parameters (Fluid Delivery Setup)

5. Select **OK**.
6. Select **Yes** to confirmation window to save the changes.

15.4.1 Fluid Delivery Setup Configurable Items

Configurable Item	Description
Priming Source	Sets the syringe to be used for priming the tubing. Select A to configure Syringe A (contrast) to be the priming source. Select B to configure Syringe B (saline) to be the priming source.
Test Inject	Enable or disable test injection. Sets the default flow rate, volume, and duration for the test injection.
Protocol Programming Mode	Sets the programming mode to enable the system to calculate the Duration, Flow Rate, or Volume. Programming Modes: <ul style="list-style-type: none"> ◆ Calculate Flow Rate: System calculates the flow rate based on volume and duration. ◆ Calculate Volume: System calculates the volume based on flow rate and duration. ◆ Calculate Duration: System calculates the duration based on flow rate and volume. ◆ Disable: Default setting. System calculates the duration based on flow rate and volume.
Total Volume Display	Sets the total volume to display the volumes in Syringe A and Syringe B or the total in Syringe A and B combined.
Auto Retract	Enables or disables the Auto Retract feature to retract the piston after a syringe is removed.
Auto Advance	Enable or disables the Auto Advance feature to advance the piston after a syringe is installed.
Auto Load Purge Volume	Auto Load Purge Volume can be set to 10mL, 5mL, or 2mL. When using filling devices from Bayer, choose one of the following volume selections: <ul style="list-style-type: none"> ◆ 5 mL for use with 115mL syringe spike (large spike) from Bayer ◆ 2 mL for use with 65mL syringe spike (small spike) from Bayer For other filling devices, consult manufacturer's instructions for use.
Contrast Types	Set or add types of contrast. See " Section 15.4.2 - Contrast Type Setup " for more information.
Reset Protocol after Injection	Sets whether or not the protocol is reset to the factory default protocol after an injection completes.
KVO Interval	Sets the interval at which the KVO pulse is delivered. To disable KVO, set the interval to "None."
Slow Forward Load Rate	Sets the rate at which fluid is manually loaded or purged using the forward and reverse piston control buttons.
Slow Reverse Load Rate	
Fast Forward Load Rate	
Fast Reverse Load Rate	

15.4.2 Contrast Type Setup

15.4.2.1 Adding a New Contrast Type

NOTE: The system is not loaded with any contrast agent information at the time of manufacture. The operator must create the list of contrast agents by adding new contrast types. Refer to contrast manufacturer's most recent dosing information from the contrast package insert when adding contrast agents.

1. Select **Contrast Types** on the Fluid Delivery Setup screen.
2. Select **Add New (1)** on the Contrast Configuration screen.

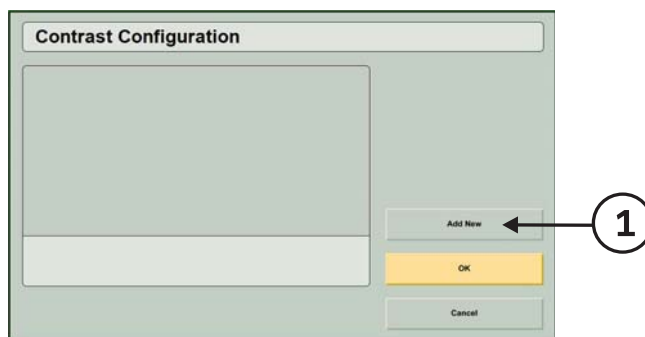

3. Edit information for each of the following items by selecting a tab (2) on the left of the screen and entering the parameters:

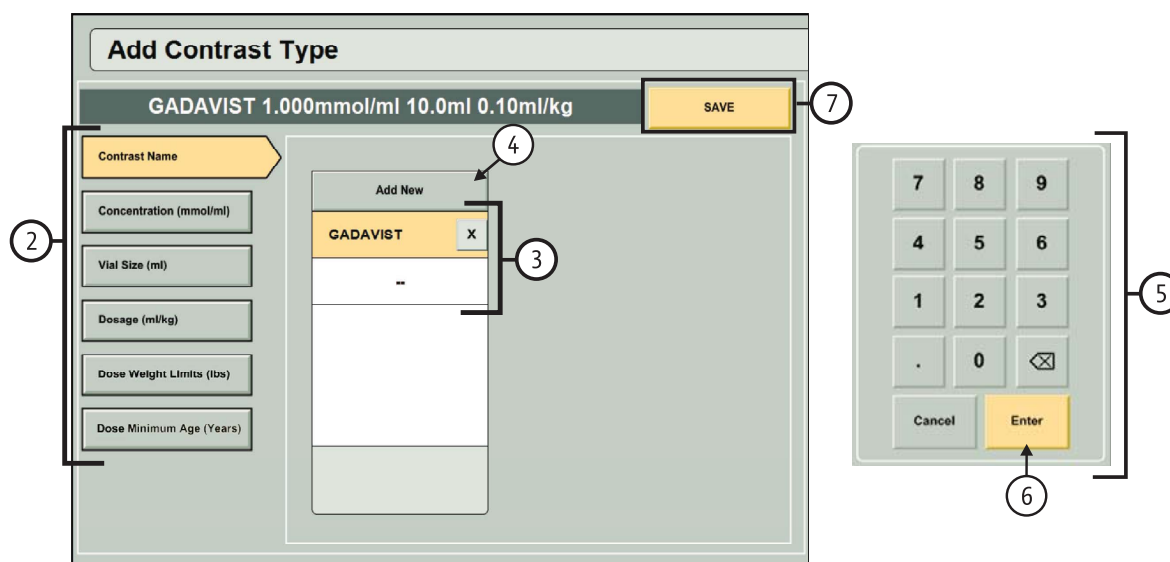

Figure 15 - 12: Adding a New Contrast Type

- ◆ Contrast Name: Select an existing contrast name from the list (3) or add a new contrast name by selecting Add New (4) and entering the name of the contrast using the keyboard window that will appear on the display. Select Enter to save the new contrast name to the list. Select the contrast name from the list.
- ◆ Concentration: Select an existing concentration from the list (3) or add a new concentration by selecting Add New (4) and entering the concentration (5). Select Enter (6) to save the new concentration to the list. Select the concentration from the list.
- ◆ Vial Size: Select an existing vial size from the list (3) or add a new vial size by selecting Add New (4) and entering the vial size (5). Select Enter (6) to save the new vial size to the list. Select the vial size from the list.
- ◆ Dosage: Select an existing dosage from the list (3) or add a new dosage by selecting Add New (4) and entering the dosage (5). Select Enter (6) to save the new dosage to the list. Select the dosage from the list.
- ◆ Weight Range: Enter the weight range identified on the contrast package insert.
- ◆ Minimum Age: Enter the minimum age identified on the contrast package insert.

NOTE: A saved value can be deleted from the list by pressing the X button. Select Yes in the message window to confirm deletion. Deleting a value will also delete any saved contrast types using that value.

4. Once the contrast name, concentration, vial size, and dosage have been selected, a Save (7) button will appear at the top of the screen. Review the selections in the header and select **Save** to save the Contrast Type. Select Yes on the message window to confirm.

5. Select **OK** to save all changes and exit Contrast Configuration.

15.4.2.2 Editing an Existing Contrast Type

NOTE: When using the Weight Based Dosing Calculator, if the operator changes the dose, the new dose will be used for the calculation only and will not affect the labeled dose saved with the contrast type. Refer to "[Section 9.3.2 - Using the Weight Based Dosing Calculator](#)" for additional information.

1. Select **Contrast Types** on the Fluid Delivery Setup screen.
2. Select a saved Contrast Type (1) on the Contrast Configuration screen and select Edit (2).

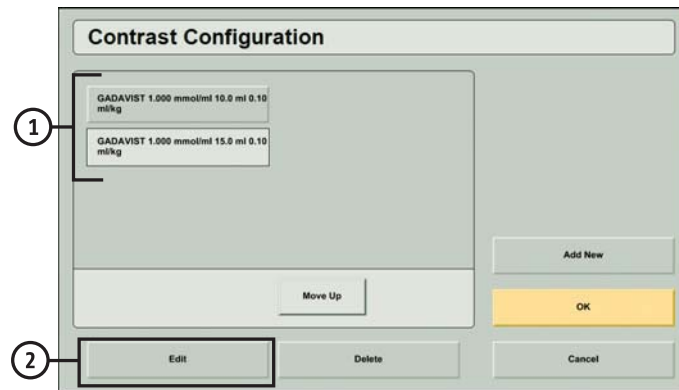

Figure 15 - 13: Select an Existing Contrast Type to edit

3. Edit information for each of the following items by selecting a tab on the left of the screen and entering the parameters (See Figure 15 - 14):
 - ◆ Contrast Name: Select an existing contrast name from the list (3) or add a new contrast name by selecting Add New (4) and entering the name of the contrast using the keyboard window that will appear on the display. Select Enter to save the new contrast name to the list. Select the contrast name from the list.
 - ◆ Concentration: Select an existing concentration from the list (3) or add a new concentration by selecting Add New (4) and entering the concentration (5). Select Enter (6) to save the new concentration to the list. Select the concentration from the list.
 - ◆ Vial Size: Select an existing vial size from the list (3) or add a new vial size by selecting Add New (4) and entering the vial size (5). Select Enter (6) to save the new vial size to the list. Select the vial size from the list.
 - ◆ Dosage: Select an existing dosage from the list (3) or add a new dosage by selecting Add New (4) and entering the dosage (5). Select Enter (6) to save the new dosage to the list. Select the dosage from the list.
 - ◆ Weight Range: Enter the weight range identified on the contrast package insert.
 - ◆ Minimum Age: Enter the minimum age identified on the contrast package insert.
4. Once a contrast name, concentration value, vial size, and dosage have been selected, select Save (7) to save the Contrast Type. Select Yes on the message window to confirm.
5. Select OK to save all changes and exit Contrast Configuration.

NOTE: A saved value can be deleted from the list by pressing the X button. Select Yes in the message window to confirm deletion. Deleting a value will also delete any saved contrast types using that value.

NOTE: If no changes were made, a message alerting the operator that a contrast type with those parameters already exists will display when attempting to save the contrast type. Select OK to close the message window. Edit a parameter to save the edited contrast type or select Cancel to return to the Contrast Configuration screen without making any changes.

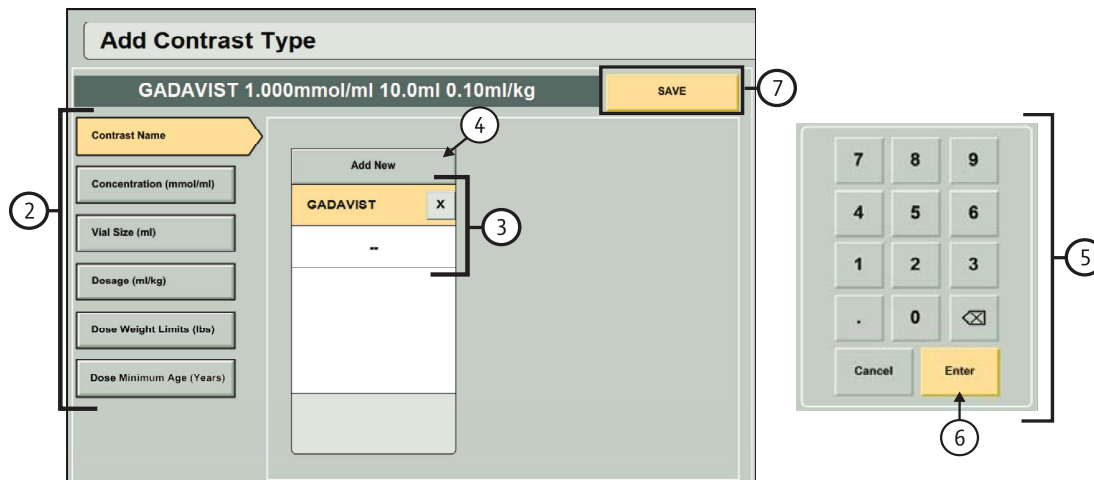

Figure 15 - 14: Editing an Existing Contrast Type

15.4.2.3 Contrast Type Management

- ◆ When two or more contrast types have been saved, the order can be changed by using the Move Up and Move Down buttons on the Contrast Configuration screen.
- ◆ To delete a saved contrast type, select the Contrast Type on the Contrast Configuration screen and select Delete. Select Yes to confirm deletion.

15.5 Help

From the Help screen, users can view applicable patent information, licensed features, and the software version their system is running. Information regarding the operation manual and Bayer HealthCare Services can also be found on Help screen.

15.5.1 Accessing the Help System

1. Access the system settings by opening the **Launch Menu** (1).
2. From the Launch Menu, select **Help** (2).

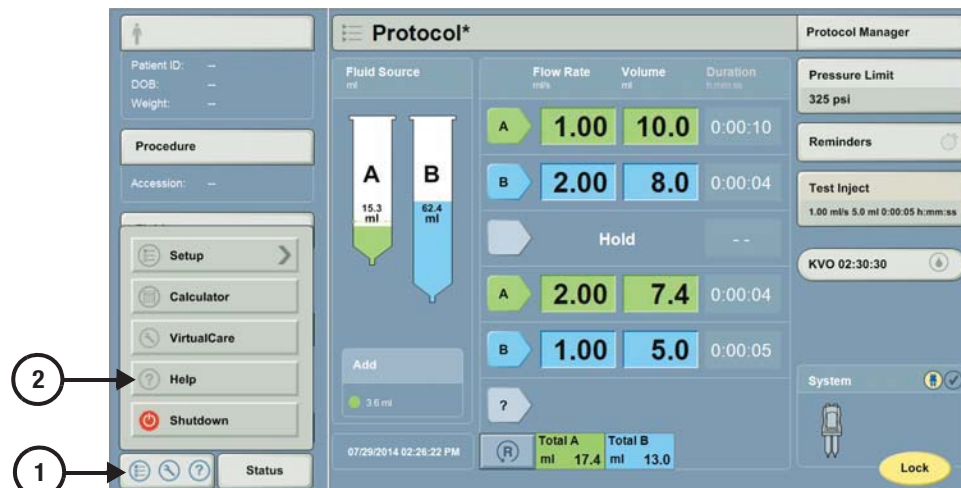

Figure 15 - 15: Help System



Figure 15 - 16: Help System Navigation

15.6 Status

If available, Status provides an indication of system status information. When selected, Status will display information that may be beneficial when placing service support requests.



Figure 15 - 17: Status



16 System Messages

The system will display messages on the screen as conditions or events occur. There are three types of basic messages:

- ◆ Type 1 messages
- ◆ Type 2 messages
- ◆ Type 3 messages

16.1 Type 1 Messages

Type 1 messages provide information regarding the current system status and will clear automatically. These messages typically display in the lower right corner of the screen.

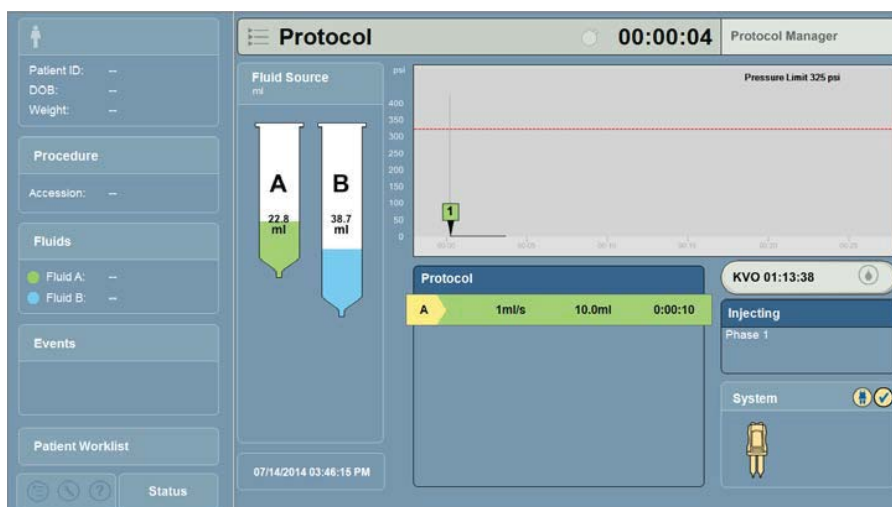

Figure 16 - 1: Type 1 Message Example

16.2 Type 2 Messages

Type 2 messages convey information that must be explicitly acknowledged before proceeding. After reading the message and performing the appropriate action (if necessary), press the button(s) within the yellow dialog box to close the message.

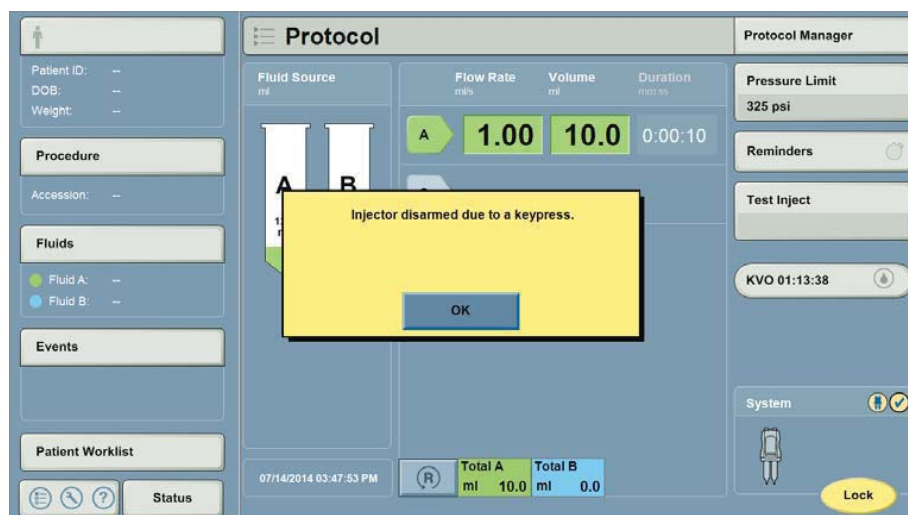

Figure 16 - 2: Type 2 Message Example

16.3 Type 3 Messages

WARNINGS

Patient injury may result from a system malfunction.

- ◆ If a system malfunction occurs, immediately disconnect the patient from the system.
- ◆ If a fault message is displayed that cannot be corrected and/or the system is not operating correctly, do not use the injection system. Call Bayer HealthCare Services for assistance.

Type 3 messages are system malfunction messages and require power to be removed from the system. Some type 3 messages provide suggestions to prevent the condition from reoccurring. If the condition cannot be corrected, record the code and number from the lower left corner of the dialog box and call Bayer HealthCare Services for assistance.

A Critical Error Has Occurred

PODMgrSwitchContactsShort
Disconnect the patient from the injector.
Turn the injector off.
Then, turn the injector on and perform a trial injection.
If the system performs correctly, return the system to use.
If the error persists, record the code below and contact Services at
<http://www.radiology.bayer.com>

SymCode FAIL
 Errnum -4104

Select "Contact Service" to request support via VirtualCare, or refer to the operations manual or the internet at:
<http://www.radiology.bayer.com>

A Critical Error Has Occurred

Non-operational process: InjectorApplication.
Disconnect the patient from the injector.
Turn the injector off.
Then, turn the injector on and perform a trial injection.
If the system performs correctly, return the system to use.
If the error persists, record the code below and contact Services at
<http://www.radiology.bayer.com>

SymCode FAIL
 Errnum

Select "Contact Service" to request support via VirtualCare, or refer to the operations manual or the internet at:
<http://www.radiology.bayer.com>

Figure 16 - 3: Type 3 Message Example

17 Maintenance and Checkout

- ◆ ["Daily"](#)
- ◆ ["Monthly"](#)
- ◆ ["Annually"](#)

WARNINGS

Electro-Mechanical Hazard - Serious injury or death may result from exposure to hazardous voltages existing within the system.

- ◆ Do not remove any covers or disassemble the injector.
- ◆ Inspect for loose or frayed cables, loose covers, cracks, dents, or loose hardware. Contact Bayer HealthCare Services or your local dealer for service or repairs.
- ◆ Do not expose system components to excessive amounts of water or soap solutions.
- ◆ Disconnect the system from line power before cleaning.

This section contains recommended procedures for maintenance and an operational checkout of the system. Routine maintenance and inspection will:

- ◆ Ensure continued performance of the system.
- ◆ Reduce the possibility of equipment malfunction.

The system must be properly maintained to ensure it is in peak operating condition. Your individual maintenance schedule depends upon how your system is used, the type of procedures performed, and frequency of use.

NOTE: For all body fluid spills, follow facility decontamination procedures.

NOTE: If contrast medium has leaked inside any component of the system, call your Services representative.

NOTE: Failures which occur due to lack of proper maintenance will not be covered under warranty.

NOTE: Services will make available upon request:

- Circuit diagrams, components part lists, or other information that will assist qualified technicians to repair components classified as repairable.
- On-site consulting or consulting references.

17.1 Daily

Before use each day, the system should be cleaned and inspected as needed using the procedures outlined in this section. The pistons should be thoroughly cleaned as needed. Ensure that all system safety and warning labels are in place and are legible. Disconnect the system from line power before cleaning.

The following procedures are recommended for daily cleaning and inspection of all components in the system. If any defects are detected, repair the system or call Bayer HealthCare Services for service. Do not use the system until the problem is corrected.

17.1.1 Cleaning the Injector Head, Syringe Piston, Syringe Interface, and Scan Room Unit Power Supply

Carefully clean the assembly using a soft, non-abrasive cloth, warm water, and a mild soap solution.

1. Fully advance the piston using the forward piston controls or manual knobs.
2. Disconnect the system from line power.

3. Place the injector head in a vertical position.
4. Clean the piston.
5. Thoroughly dry the piston.
6. Clean the inner area of the syringe interface. (Retracting the pistons at this point may allow better cleaning of the syringe interfaces. Use the manual knobs to retract the pistons.)
7. Wipe the injector head case and control panel.
8. Thoroughly dry the injector head case and control panel.
9. Wipe the scan room unit power supply. Do not use an excessive amount of fluid when cleaning the power supply.
10. Thoroughly dry the scan room unit power supply.

17.1.2 Cleaning the Pedestal

Clean the pedestal and integrated IV pole as needed with warm water and mild soap solution.

17.1.3 Inspecting the Injector Head and Mounting

- ◆ Inspect the housing for any damage or cracks that could allow fluid to leak inside or weaken the structural integrity of the unit.
- ◆ Inspect all cables connected to the unit. Look for cuts, cracks, worn spots, or other obvious damage to the cables. Ensure that all connectors are properly seated.
- ◆ Inspect for contrast media build-up in the syringe interface area. Follow the cleaning guidelines outlined above.
- ◆ Inspect the stand and support arm for cracks and other defects that could weaken the structure.
- ◆ Ensure that all mounting bolts and screws are secure.
- ◆ Ensure that all locking mechanisms on the casters are functional.
- ◆ Inspect the pivot points. The head and support arm must pivot freely.
- ◆ Ensure that the casters roll smoothly with no binding or scraping.
- ◆ Inspect the pedestal for loose or damaged components. Tighten or repair as necessary.

NOTE: All relevant guidelines for facility, local, or national safety recommendations related to cable routing and installation should be followed.

NOTE: Contact Bayer HealthCare Services or your local dealer for service or repairs

17.1.4 Cleaning the Display

NOTICE

Electro-Mechanical Hazard - Equipment Damage may result.

- ◆ Do not spray cleaning solutions directly onto the display screen.

Wipe the touch screen with a soft, non-abrasive cloth or a paper towel dampened with mild soap solution.

17.1.5 Inspecting the Display

- ◆ Inspect all cables connected to the unit. Look for cuts, cracks, worn spots, or other obvious damage. Ensure that all connectors are properly seated.
- ◆ Inspect the housing for any damage or cracks that could allow fluid to leak inside or weaken the structural integrity of the unit.

17.2 Monthly

Once a month, the entire system should be thoroughly inspected and cleaned and an operational checkout should be performed. Disconnect the system from line power before cleaning. If any defects are detected, either repair the system or call Bayer HealthCare Services for service. Do not use the system until the problem is corrected.

17.2.1 Operational Checkout

A basic functional checkout of the system should be included as part of regular maintenance. Verifying proper operation of the system will help in detection of any problems that may not be noticed in day-to-day operation. The following procedure represents a suggested series of activities that encompass typical operation of the system. Read the following procedure carefully before beginning the checkout. If problems are detected, call your Services representative.

NOTE: Any problems detected during this or any other procedure should be addressed before using the system in patient procedures.

System Labels

- ◆ Ensure that all system safety and warning labels are in place and legible.

Power Up

1. Apply power to the system.
2. Verify that the Safety Screen displays.
3. Press **Continue** to acknowledge the messages on the Safety Screen.
4. Verify that all displays and indicators are functioning properly.
5. Verify that the "[Section 7.1 - Injector Head Lights and Indicators](#)" on the injector head are functioning. All lights should blink during power up.

Programming

Once the Home Screen displays, verify that the following controls are functioning properly:

1. Fully advance and reverse the pistons by pressing the Enable Piston Control button and using the forward/reverse piston controls.
2. Ensure that Auto Advance and Auto Retract are enabled.
3. Enter and lock the following protocol:

		<u>Flow Rate</u>	<u>Volume</u>
Phase 1:	Syringe A:	10 mL/s	20 mL
Phase 2:	Syringe B:	2.5	10
Phase 3:		PAUSE	5 seconds
Phase 4:	Syringe A:	5.0	10
Phase 5:	Syringe B:	0.1	1

4. Install Bayer syringes and ensure the piston automatically docks and fully advances the syringe plungers.
5. Perform Auto Fill.
6. Arm and initiate an injection.
7. In one of the phases, activate the HOLD feature for at least ten seconds by pressing the Start/Pause button mid-injection.

8. Resume the injection and verify the injection completes normally and that the Injection Complete screen displays the results.
9. Advance plungers to the full forward position, remove syringes, and ensure that the pistons automatically retract.
10. Power down the injector.

17.3 Annually

Once a year, a system calibration and leakage check should be performed by a qualified Services representative. Bayer offers preventative maintenance programs. These annual maintenance programs greatly assist in maintaining accuracy and reliability and can extend the life of the system. Contact your local Bayer office or your local authorized dealer for information. Refer to the back of this manual for address, telephone, and fax information.

17.3.1 Injection System Calibration

Bayer recommends a complete system calibration and performance checkout be performed annually. Contact Bayer HealthCare Services or your local Bayer office for complete details.

17.3.2 Checking Electrical Leakage

As part of an annual maintenance program performed by a qualified Services representative or authorized dealer, both electrical leakage and protective earth ground continuity checks should be performed.

NOTE: Local regulations or facility protocol may require electrical leakage checks at more frequent intervals. If this applies, the local regulations for leakage must be followed.

18 Specifications

18.1 Display Specifications

18.1.1 Display Dimensions

NOTE: Listed dimensions are approximate. Display color may vary.

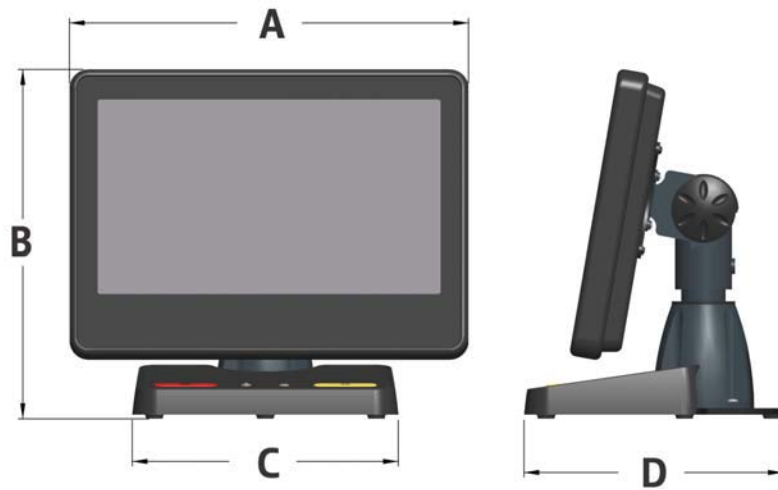

	Black Display	White Display
A	15.75 in 40.00 cm	15.58 in 39.58 cm
B	13.46 in 34.19 cm	12.71 in 32.28 cm
C	10.50 in 26.67 cm	10.50 in 26.67 cm
D	10.23 in 25.98 cm	10.23 in 25.98 cm
Weight	17.6 lbs 8.0 kg	17.6 lbs 8.0 kg

18.1.2 Display Connections

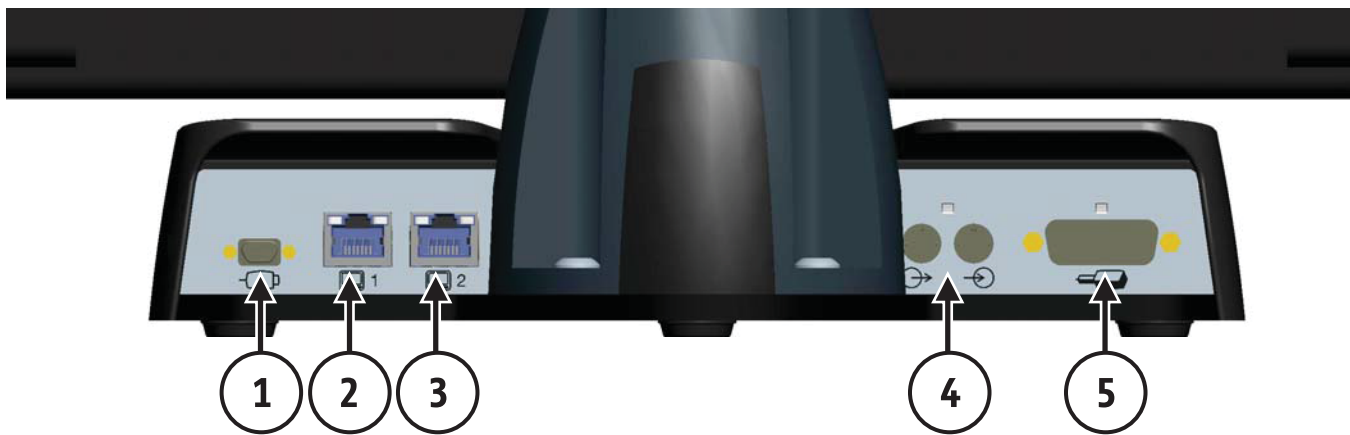

1	Hand Switch connection	2	Ethernet connection (Bayer HealthCare Services use only)
3	Ethernet connection 2 (to the display)	4	Fiber optic connections
5	Power Supply connection		

18.1.3 Display Input Power Requirements

100-240 VAC

47-63 Hz

1.6A

18.1.4 Pod Input Power Requirements

100-240 VAC

50-60 Hz

0.35A

18.2 Injector (Scan Room Unit) Specifications

18.2.1 Injector (Scan Room Unit) Dimensions

NOTE: Listed dimensions are approximate.

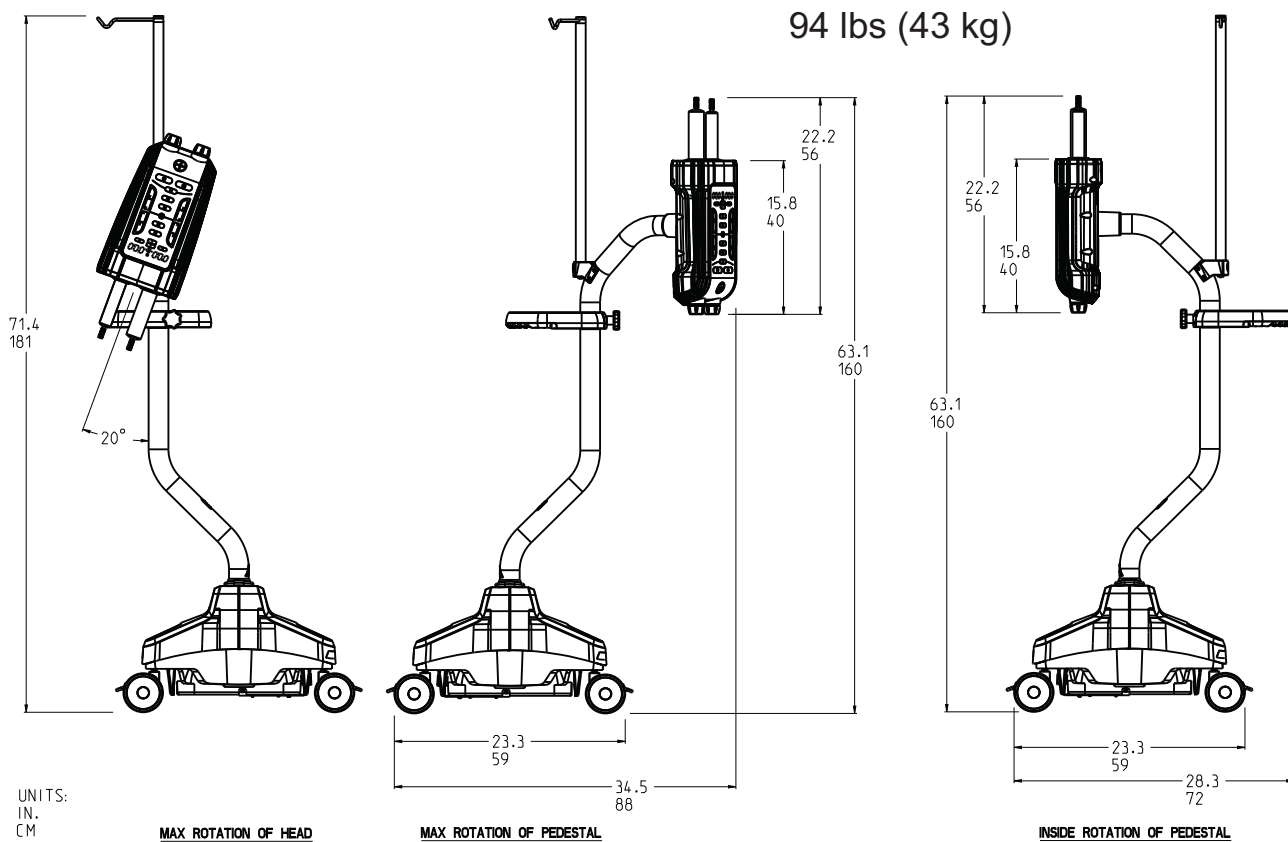

18.2.2 Scan Room Unit Power Supply Dimensions

(1) AC Main Power Input and Main Power Switch

(2) Scan Room Unit Power and Output

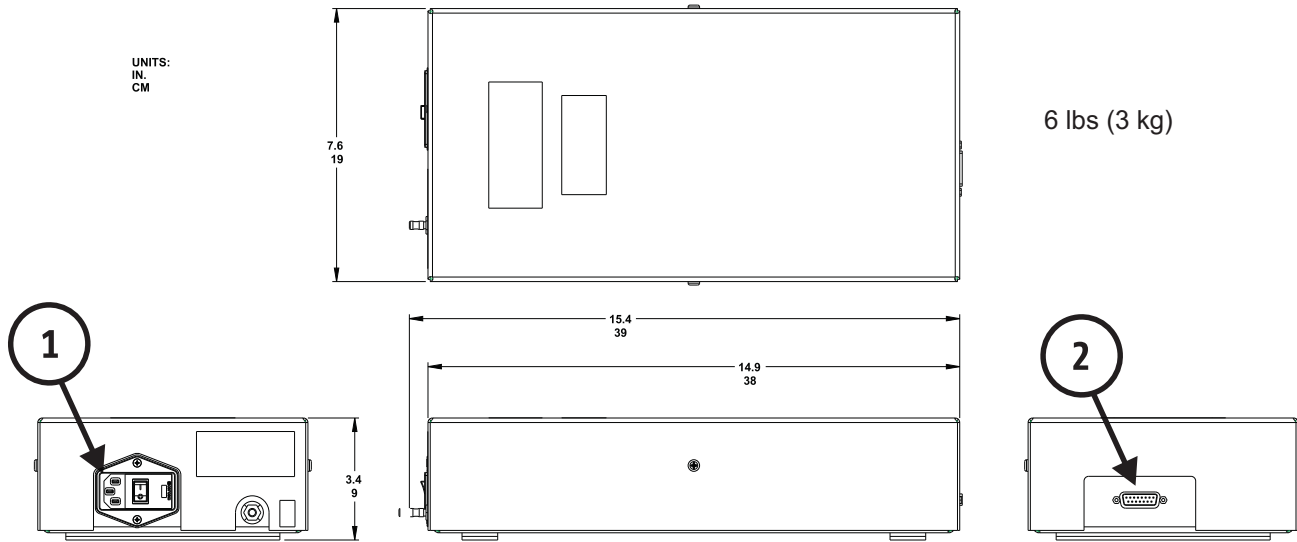

18.2.3 Input Power Requirements

100-240 VAC

50/60 Hz

120VA - 210VA

18.3 Environmental Specifications

18.3.1 Non-Operating (Transportation and Storage)

Temperature: -20°C to 60°C (-4°F to +140°F)

Humidity: 5% to 100% R.H.

Atmospheric Pressure: 57 kPa to 106 kPa

18.3.2 Operating

The system may not meet all performance specifications if operated outside of the following conditions:

Temperature: +10°C to +35°C (+50°F to +95°F)

Humidity: 20% to 90% R.H., non-condensing

Atmospheric Pressure: 70 kPa to 103 kPa

18.3.3 Protection Against Electrical Shock

Per IEC60601-1:2012 (Edition 3.1), the system is designed as a Class 1 Medical Device with a type BF applied part.

Type BF corresponds to the degree of protection against electrical shock by the applied part of the Medical Device. Class 1 equipment requires a protective earth connection (electrical grounding) to ensure protection against electrical shock in the event of a failure of the basic insulation system. The following are requirements for a Class 1 Type BF Medical Device:

18.3.3.1 Electrical Leakage

Complies with EN, UL, CSA, and IEC requirements for safe Electrical Leakage Current limits for Medical Equipment:

Earth Leakage Current:	< 500 microamps (Normal Condition)
Chassis (Touch) Leakage Current:	< 100 microamps (Normal Condition)
Patient Connection Leakage Current:	< 100 microamps, a.c. (Normal Condition)

18.3.4 EMI/RFI

The injector system is classified as Group 1, Class B equipment per the requirements of EN/IEC 60601-1-2:2007. Accessories provided by Bayer comply with this standard.

18.3.5 Protection Against the Ingress of Fluids

Per IEC60601-1:2012 (Edition 3.1), the scan room unit has been classified as drip-proof equipment. The components of the system scan room unit are provided with an enclosure that prevents the entry of such an amount of falling liquid as might interfere with the safe operation of the injector, indicated by the IPX1 designation on the injector head. The scan room unit power supply, Pod power supply, and display power supply, along with the display, and all other control room equipment are classified IPX0. Care must be taken to prevent spilling fluids on these power supplies, displays, and control room equipment.

18.3.6 Mode of Operation

Per IEC60601-1:2012 (Edition 3.1) the mode of operation for the control room unit is continuous operation. It will operate under normal load for an unlimited period, without excessive temperature being developed.

The mode of operation for the scan room unit is continuous operation. Under normal operating conditions with a minimum of 10 minutes between injections, the internal temperature of the scan room unit will not rise enough to degrade system performance, reliability, or safety.

18.4 System Capabilities

SYRINGE A:	Disposable 65 mL	
SYRINGE B:	Disposable 115 mL	
VOLUME (Programmable):	SYRINGE A:	0.5 mL to max. syringe volume in:
		0.1 mL increments up to 31 mL
		1 mL increments above 31 mL
	SYRINGE B:	1 mL to max. syringe volume in 1 mL increments
FLOW RATE (Programmable):	0.01 to 10 mL/s in:	0.01 mL/s increments between .01 and 3.1 mL/s
		0.1 mL/s increments between 3.1 and 10mL/s
KVO (Programmable):	0.25 mL every:	15 seconds
		20 seconds
		30 seconds (default)
		45 seconds
		60 seconds
		75 seconds
PROGRAMMABLE PRESSURE LIMIT (PSI/kPa):	100/690	
	150/1035	
	200/1380	
	250/1725	
	300/2070	
	325/2240 (default)	
INJECTION & POST-INJECTION REMINDERS	1 to 1200 seconds in 1 second increments	
PAUSE PHASE:	1 to 1200 seconds in 1 second increments	
INJECTION	6 phases per protocol	
STORAGE CAPACITY:	60 protocols of up to 6 phases each	

18.5 Approximate Heat Generation

- ◆ Control Room Unit (Display and Pod): 675 BTU/hour
- ◆ Scan Room Unit with Power Supply: 660 BTU/hour

18.6 Over and Under Infusion Protection

The following means are provided to protect against over and under infusions:

- ◆ Warnings displayed on the Safety Screen to remind the operator to check the programmed injection parameters prior to the injector being armed.
- ◆ An on-screen indication of insufficient volume is provided whenever the total volume programmed to be delivered is greater than the amount of fluid in the syringe.
- ◆ Injection monitoring is performed in the injector head to detect over rate or over volume conditions due to system faults. The delivered volume is also monitored against the total programmed volume for the injection.
- ◆ When a fault caution, hold, or stop is detected, the injection will stop within 5mL.
- ◆ Once the system has disarmed, a tone sounds and a stall message appears on the display.

18.7 System Fluid Performance

The injector's ability to generate pressure is only one factor affecting maximum flow rates. Other factors include:

- ◆ Catheter diameter
- ◆ Viscosity of the fluid
- ◆ Tube length
- ◆ Number of tubing sections
- ◆ Tube diameter
- ◆ Temperature of the fluid, tube, and syringes during the injection
- ◆ Maximum pressure setting on the injector

To illustrate the wide range of maximum flow rates, a number of laboratory tests were performed using the MEDRAD® MRXperion injector, Saline 0.9% solution and differing contrast types and concentrations. Tests also included the MEDRAD® MRXperion Low Pressure Connector Tubing, four catheter sizes (18, 20, 22, and 24 gauge), temperatures from 21°C to 23°C (70°F to 73°F), all at maximum pressure of 325 PSI. The maximum flow rates of injectors were tested with over 50 combinations of the preceding items. The maximum flow rates ranged from 2.6 - 10.0 mL/second.

If the user experiences problems achieving the desired flow rate please contact a Clinical representative for suggestions that may increase it.

18.8 System Performance

Volume Accuracy:	Syringe A: +/- (1% + 0.2ml) of the programmed contrast volume for volumes ≤ 15.0 ml +/- (1% + 0.3ml) of the programmed contrast volume for volumes >15.0 ml Syringe B: +/- (5% + 0.1mL)
Flow Rate Accuracy:	+/- (10% + 0.005 mL/s) when rate is 0.01 to 0.99 mL/s +/- (10% + 0.02 mL/s) when rate is 1 to 10 mL/s
Pause Accuracy:	+/- (5% + 0.2 second)
Displayed Pressure Accuracy:	+/- 25 psi, measured at 200 psi
KVO Volume Accuracy:	+/- 0.05 mL, averaged over 10 consecutive boluses
KVO Flow Rate Accuracy:	1 mL/s +/- 0.2 mL/s

18.9 Forward and Reverse Controls

Low speed: 2.5 mL/s (default) High speed: 10 mL/s (default)

Low speed is selectable from 1.0 to 10.0 mL/s in 0.5 mL/s increments.
High speed is selectable from 1.0 to 10.0 mL/s in 0.5 mL/s increments.

18.10 Ground Continuity

The resistance from the earth ground connector at the plug end of the AC mains power cord to any exposed metal on the scan room unit or power supply enclosure shall be less than 0.2 ohms.

18.11 Classifications

Flammable Anesthetics: The system is not suitable for use in the presence of a flammable anesthetic mixture with air, oxygen, or nitrous oxide.

19 Options and Accessories

19.1 MEDRAD® MRXperion MR Injection System

	Catalog Number
MEDRAD® MRXperion MR Injection System	MRXP 200

19.2 MEDRAD® MRXperion Injection System Syringe Kit

	Catalog Number
65/115 mL Syringes with 96" Low Pressure T-Connector Tube with Check Valve and Two Spikes	XP 65/115 VS

19.3 Hand Switch

	Part Number
Hand Switch	3006265

19.4 IV Poles

	Part Number
Single Hook IV Pole	3042322
Double Hook IV Pole	3018637

19.5 Manuals

	Part Number
Multi-lingual Operators Manual CD	3038565
Service Manual (English)	3038661
Installation Manual	3041584

19.6 Penetration Panel Filter Kit

	Part Number
Penetration Panel Filter Kit	84680761



20 Compliance to EN/IEC 60601-1-2: 2007

Special precautions regarding Electromagnetic Compatibility (EMC), are required for installation and use of this system.

The system complies with the requirements of:

- ◆ EN 60601-1-2:2007 Medical Electrical Equipment-Part 1: General Requirements for Safety, Amendment No. 2. Collateral Standard: Electromagnetic Compatibility Requirements and Tests.
- ◆ EN 55011:2009/A1:2010 Limits and methods of measurement of radio disturbance, characteristics of industrial, scientific and medical radio frequency equipment.
- ◆ EN 61000-3-2:2006/A2:2009 edition - Electromagnetic Compatibility - Part 3: Testing and measurement techniques - Section 2: Harmonic current emissions test.
- ◆ EN 61000-3-3:2008 edition - Electromagnetic Compatibility - Part 3: Testing and measurement techniques- Section 3: Voltage fluctuation and flickers test.
- ◆ EN 61000-4-2:2009 edition - Electromagnetic Compatibility - Part 4: Testing and measurement techniques- Section 2: Electrostatic discharge immunity test.
- ◆ EN 61000-4-3 /A2:2010 edition - Electromagnetic Compatibility - Part 4: Testing and measurement techniques- Section 3: Radiated, radio-frequency, electromagnetic field immunity test.
- ◆ EN 61000-4-4:2004/A1:2010 edition - Electromagnetic Compatibility - Part 4: Testing and measurement techniques- Section 4: Electrical fast transient / Burst immunity test.
- ◆ EN 61000-4-5:2006 edition - Electromagnetic Compatibility - Part 4: Testing and measurement techniques- Section 5: Surge immunity test.
- ◆ EN 61000-4-6:2009 edition - Electromagnetic Compatibility - Part 4: Testing and measurement techniques- Section 6: Conducted immunity test.
- ◆ EN 61000-4-8:2010 edition - Electromagnetic Compatibility - Part 4: Testing and measurement techniques- Section 8: Power frequency magnetic field immunity test.
- ◆ EN 61000-4-11:2004 edition - Electromagnetic Compatibility - Part 4: Testing and measurement techniques- Section 11: Voltage dips and interruptions immunity test.

NOTICE

Electro-Mechanical Hazard - Equipment Damage may result or system may fail to operate.

- ◆ Do not expose to high magnetic fields. Portable and mobile RF communications equipment can affect the system.
- ◆ Use only accessories and options from Bayer that are designed specifically for the system. Other non-Bayer accessories or options may cause equipment damage or may result in increased emissions or decreased immunity of the system. System accessories listed in this manual comply with the requirements of electromagnetic emissions and immunity standards EN/IEC 60601-1-2:2007 (Edition 3).
- ◆ If adjacent or stacked use is necessary, the system should be observed to verify normal operation in the configuration in which it will be used.

Recommended Separation Distances Between Portable and Mobile RF Communications Equipment and the System

The system is intended for use in an electromagnetic environment in which radiated RF disturbances are controlled. The customer or the operator of the system can help prevent electromagnetic interference by maintaining a minimum distance between portable and mobile RF communications equipment (transmitters) and the system as recommended below, according to the maximum output power of the communications equipment.

Rated Maximum Output Power of Transmitter (W)	Separation Distance According to Frequency of Transmitter (m)		
	150 KHz to 80 MHz $d = \left[\frac{3.5}{V_1} \right] \sqrt{p}$	80 MHz to 800 MHz $d = \left[\frac{3.5}{E_1} \right] \sqrt{p}$	800 MHz to 2.5 GHz $d = \left[\frac{7}{E_1} \right] \sqrt{p}$
0.01	0.12	0.12	0.23
0.1	0.37	0.37	0.74
1	1.17	1.17	2.33
10	3.69	3.69	7.38
100	11.67	11.67	23.33

For transmitters rated at a maximum output power not listed above, the recommended separation distance d in meters (m) can be estimated using the equation applicable to the frequency of the transmitter, where p is the maximum output power rating of the transmitter in watts (W) according to the transmitter manufacturer.

NOTE 1: At 80 MHz and 800 MHz, the separation distance for the higher frequency applies.

NOTE 2: These guidelines may not apply in all situations. Electromagnetic propagation is affected by absorption and reflection from structures, objects, and people.

SYSTEM REQUIRES SPECIAL PRECAUTIONS REGARDING EMC. Install and put into service according to the EMC information provided below.

Guidance and Manufacturer's Declaration - Electromagnetic Emissions

The system is intended for use in the electromagnetic environment specified below. The customer or operator of the system should assure that it is used in such an environment.

Emissions Test	Compliance	Electromagnetic Environment - Guidance
RF emissions CISPR 11	Group 1	The system uses RF energy only for its internal function. Therefore, its RF emissions are very low and are not likely to cause any interference in nearby electronic equipment.
RF emissions CISPR 11	Class B	The system is suitable for use in all establishments, including domestic establishments and those directly connected to the public low-voltage power supply network that supplies buildings used for domestic purposes.
Harmonic emissions IEC 61000-3-2	Class A	
Voltage fluctuations / flicker emissions IEC 61000-3-3	Complies	

Guidance and Manufacturer's Declaration - Electromagnetic Immunity

The system is intended for use in the electromagnetic environment specified below. The customer or operator of the system should assure that it is used in such an environment.

Immunity Test	IEC 60601 Test Level	Compliance Level	Electromagnetic Environment - Guidance
Electrostatic Discharge (ESD) IEC 61000-4-2	± 6 kV contact ± 8 kV air	± 6 kV contact ± 8 kV air	Floors should be wood, concrete, or ceramic tile. If floors are covered with a synthetic material, the relative humidity should be at least 30%.
Electrical/ Fast Transient / Burst IEC 61000-4-4	± 2 kV for power supply lines ± 1 kV for input/output lines	± 2 kV for power supply lines ± 1 kV for input/output lines	Mains power quality should be that of a typical commercial or facility environment.
Surge IEC 61000-4-5	± 1 kV differential mode ± 2 kV common mode	± 1 kV differential mode ± 2 kV common mode	Mains power quality should be that of a typical commercial or facility environment.
Voltage dips, short interruptions, and voltage variations on power supply input lines IEC 61000-4-11	<5% U_T (>95% dip in U_T) for 0.5 cycle 40% U_T (60% dip in U_T) for 5 cycles 70% U_T (30% dip in U_T) for 25 cycles <5% U_T (>95% dip in U_T) for 5 sec	<5% U_T (>95% dip in U_T) for 0.5 cycle 40% U_T (60% dip in U_T) for 5 cycles 70% U_T (30% dip in U_T) for 25 cycles <5% U_T (>95% dip in U_T) for 5 sec	Mains power quality should be that of a typical commercial or facility environment. If the operator of the system requires continuous operation during power mains interruptions, it is recommended that the system be powered from an uninterruptible power supply or battery.
Power frequency (50/60 Hz) magnetic field IEC 61000-4-8	3 A/m	3 A/m	Power frequency magnetic fields should be at levels characteristic of a typical location in a typical commercial or facility environment.

NOTE: U_T is the a.c. mains voltage prior to application of the test level.

Guidance and Manufacturer's Declaration - Electromagnetic Immunity

The system is intended for use in the electromagnetic environment specified below. The customer or operator of the system should assure that it is used in such an environment.

Immunity Test	IEC 60601 Test Level	Compliance Level	Electromagnetic Environment - Guidance
Conducted RF IEC 61000-4-6	3 V _{rms} 150 kHz to 80 MHz	3 V _{rms}	<p>Portable and mobile RF communications equipment should be used no closer to any part of the system, including cables, than the recommended separation distance calculated from the equation applicable to the frequency of the transmitter.</p> <p>Recommended separation distance:</p> $d = 1.17\sqrt{p}$
Radiated RF IEC 61000-4-3	3 V/m 80 MHz to 2.5 GHz	3 V/m	<p>80 MHz to 800 MHz</p> $d = 1.17\sqrt{p}$ <p>Where <i>p</i> is the maximum output power rating of the transmitter in Watts (W) according to the transmitter manufacturer and <i>d</i> is the recommended separation distance in meters (m).</p> <p>Field strengths from fixed RF transmitters, as determined by an electromagnetic site survey^a, should be less than the compliance level in each frequency range.^b</p> <p>Interference may occur in the vicinity of equipment marked with the following symbol:</p> 

NOTE 1: At 80 MHz and 800 MHz, the higher frequency range applies.

NOTE 2: These guidelines may not apply in all situations. Electromagnetic propagation is affected by absorption and reflection from structures, objects, and people.

a. Field strengths from fixed transmitters, such as base stations for radio (cellular/cordless) telephones and land mobile radios, amateur radio, AM and FM radio broadcast cannot be predicted theoretically with accuracy. To assess the electromagnetic environment due to fixed RF transmitters, an electromagnetic site survey should be considered. If the measured field strength in the location in which the system is used exceeds the applicable RF compliance level above, the system should be observed to verify normal operation. If abnormal performance is observed, additional measures may be necessary, such as reorienting or relocating the system.

b. Over the frequency range 150 kHz to 80 MHz, field strengths should be less than 3 V/m.

© 2014-2016 Bayer. All rights reserved. Reproduction of this manual is strictly prohibited without express written consent of Bayer Medical Care Inc.

Bayer, the Bayer Cross, MEDRAD, MRXperion, MEDRAD MRXperion, Certegra, Gadavist, Magnevist, Eovist, and FluiDots are trademarks of Bayer and may be registered in the US and other countries.

In accordance with data privacy and protection laws in the United States and other countries, all patient data that appear in this document are fictitious. No actual patient information is shown.

Bayer HealthCare and Bayer HealthCare Services.
For a full list of Bayer offices and authorized dealers, go to:
<http://www.radiology.bayer.com>



Bayer HealthCare

Radiology
Bayer Medical Care



UNITED STATES
Bayer Medical Care Inc.
1 Bayer Drive
Indianola, PA 15051-0780
U.S.A.
Phone: +1.412.767.2400
+1.800.633.7231
Fax: +1.412.767.4120

www.radiology.bayer.com
www.bayerhealthcare.com



EUROPE
Bayer Medical Care B.V.
Horsterweg 24
6199 AC Maastricht Airport
The Netherlands
Phone: +31 (0) 43-3585601
Fax: +31 (0) 43-3656598

JAPAN
日本モドラッド株式会社
〒530-0001
大阪市北区梅田 2-4-9
日本
電話 +81(0)66-133-6250
Fax: +81(0)66-344-2395

Bayer
拜耳
バイエル
Байер
بایر